

Keiran Ryan MODELS

PRESENTS

The NSW S008 Silo Kit in "N" Scale .

This is a complete kit of a NSW Concrete Grain Silo in N Scale, based on drawings from the Grain Handling Authority of NSW.

Read on to understand the instruction for construction of this kit



Introduction

Welcome, and I hope you enjoy this instructional presentation.

The S008 silos were constructed from 1928 until 1934 and along with there hybrid siblings, the S016 and S024 silos. They are scattered all around New South Wales. Details can be found at <https://www.krmodels.com.au/s008.html>.

This group of concrete silos is the smallest style of concrete silo in the NSW system and lend themselves really well to small or larger layouts, and can be serviced by small country trains that ran from 1928 onward.

The kit is based on the original drawings obtained from the GHA, back in the 1980's. Unlike the HO models of the same kit, this kit comes complete apart from paint and glue. (and you also need to provide a little bit of your own labour.)

The majority of this kit was produced on an FDM 3D printer, and many, many models were produced in an attempt to "Get It Right", and I am really happy with the outcome, and I hope you are as well.

As well as 3D components, there are also etched nickel silver parts, brass wire, brass "H" pattern, various small screws, a craft wood base, brass tube, and some Resin 3D parts for doors, windows and vents and styrene sheeting for the "corrugated iron cladding". And if you follow the instructions you should have a beautifully constructed silo sitting proudly on your layout, on completion.

So "LET'S GET READY TO MODEL" ----- Enjoy and learn.

What you will need (Tools and things)

As for as tools are concerned, the following would be handy to have:

- Soldering iron
- Small Screwdriver set (with a long thin bladed Phillips head (approx. 3 mm thick shaft))
- Cutting blade
- Engineers squares
- Hobby work mat
- Small engineers ruler
- Sanding Blocks
- Small file set
- Pin vices
- Glue - supa glue, 2 part epoxy
- Time, Patience, and a good work ethic.
- Other stuff that I have probably forgotten ---- S..t happens.

Parts List

- **Silo Timber Base (with “T Nuts”)**
- **Silo Base – 3D Print**
- **Silo Work House – 3D Print**
- **Silo Cupola – 3D Print**
- **Silo Cupola Base – 3D Print**
- **Silo Annex – 3D Print Flexi cable, and parts.**
- **Silo Small Roof x 2 – 3D Print**
- **Silo Out Loading Platform – 3D Print**
- **Silo Out Loading Platform Steps – 3D Print**
- **Silo Spoil Bin – 3D Print**
- **Silo Etch – Nickle Silver – (Ladder Stiles, Ladder Guard, Weighbridge, Rear Door/Grill.**
- **Silo Prints – Doors/Windows/Vents.**
- **Silo Wagon Shed Trusses and Side Purlins – 3D print**
- **Silo Wagon Shed Frame – “H” Pattern Brass x 300 mm**
- **Wagon Shed Frame jig on craft wood base**
- **Silo Outloading Pipe Kit, including 3 mm Brass Tube x 2, brass plate, 0.8 mm tube, and 0.5 mm wire**
- **Silo Winch Parts Kit, including 0.3 mm wire, 0.6 mm tube, 2 x nickel silver plate. Brass wire – 0.3 mm x 1, 0.5 mm x 1 0.6 mm x 1.**
- **Metric Drills – 1.2 mm, 1.5 mm, 2.0 mm**
- **Various Self Tapping Screws (Bagged and Labelled)**
- **Evergreen 2020 – used as corrugated cladding.**

Clean up the 3D parts (1)

It is very important to remove any flash on the 3d parts to ensure a good fit of these parts. These parts can be fragile and need to be handled carefully.

Keiran Ryan Models has a one time replacement policy on parts, and that is if the part is damaged whilst taking care to clean the part, it will be replaced, but, this will only occur once, and any postage will be the responsibility of the kit purchaser.

The 3D parts come as printed, and will need to be cleaned up so that any printed flash can be removed, especially around the base of parts. The holes may also need to be cleaned out with a drill and any burrs removed with a sanding block. Parts and holes sizes are indicated with the parts in the next couple of slides, please use the correct size drill, when cleaning out the holes.

You will need small metric drills to complete this task, (included in the kit) or the appropriate number drills can be used.

The surface of the base can be slightly rough. So you can sand the flat surfaces with a fine wet and dry paper and use a fine stop putty to fill any imperfections, that may appear.

Remember that in real life, these structures are built from concrete, and that concrete can be a rough finish at times, and then weathered. So the final finish is up to the modeller, much like the finish of a model loco, whether or not the model is weathered.

Clean up the 3D parts (2)

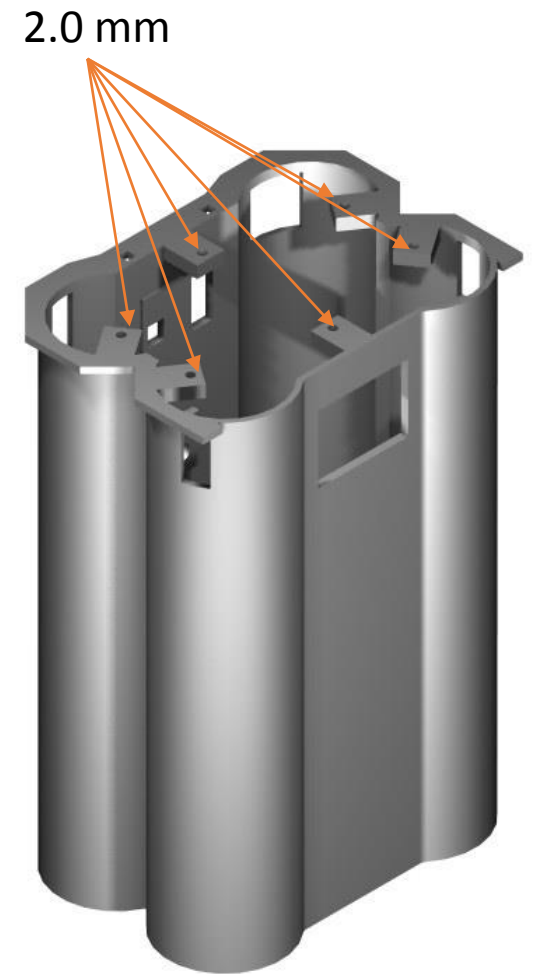
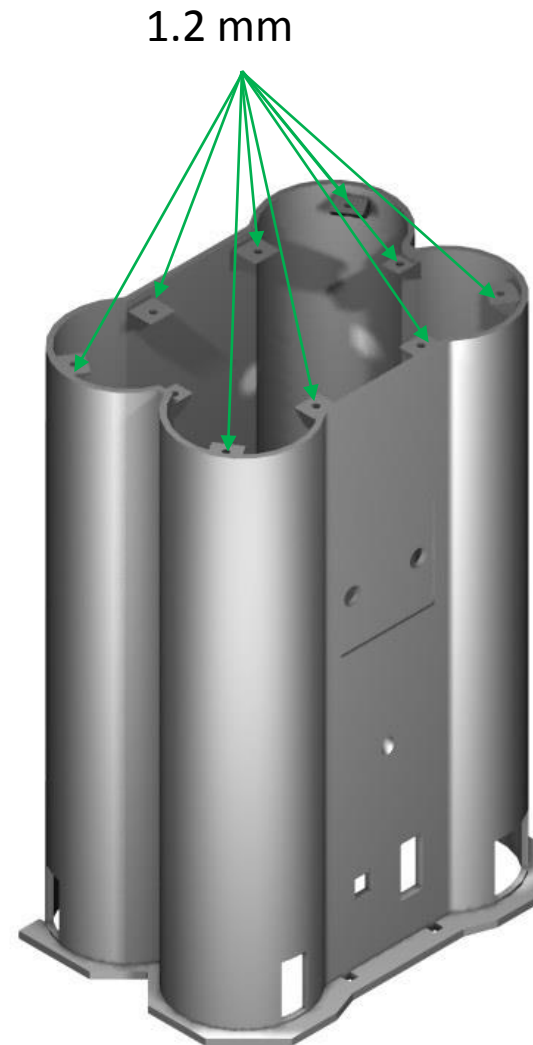
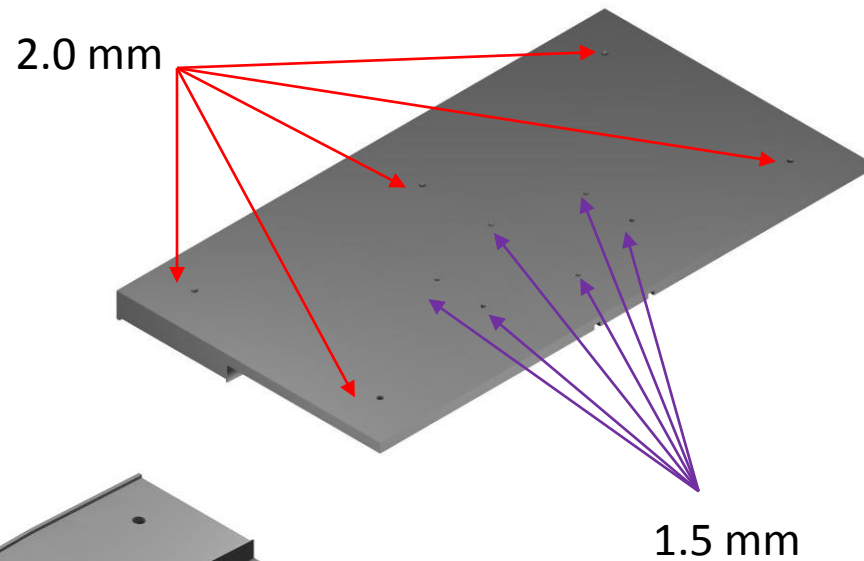

Clean up the 3D parts (3)

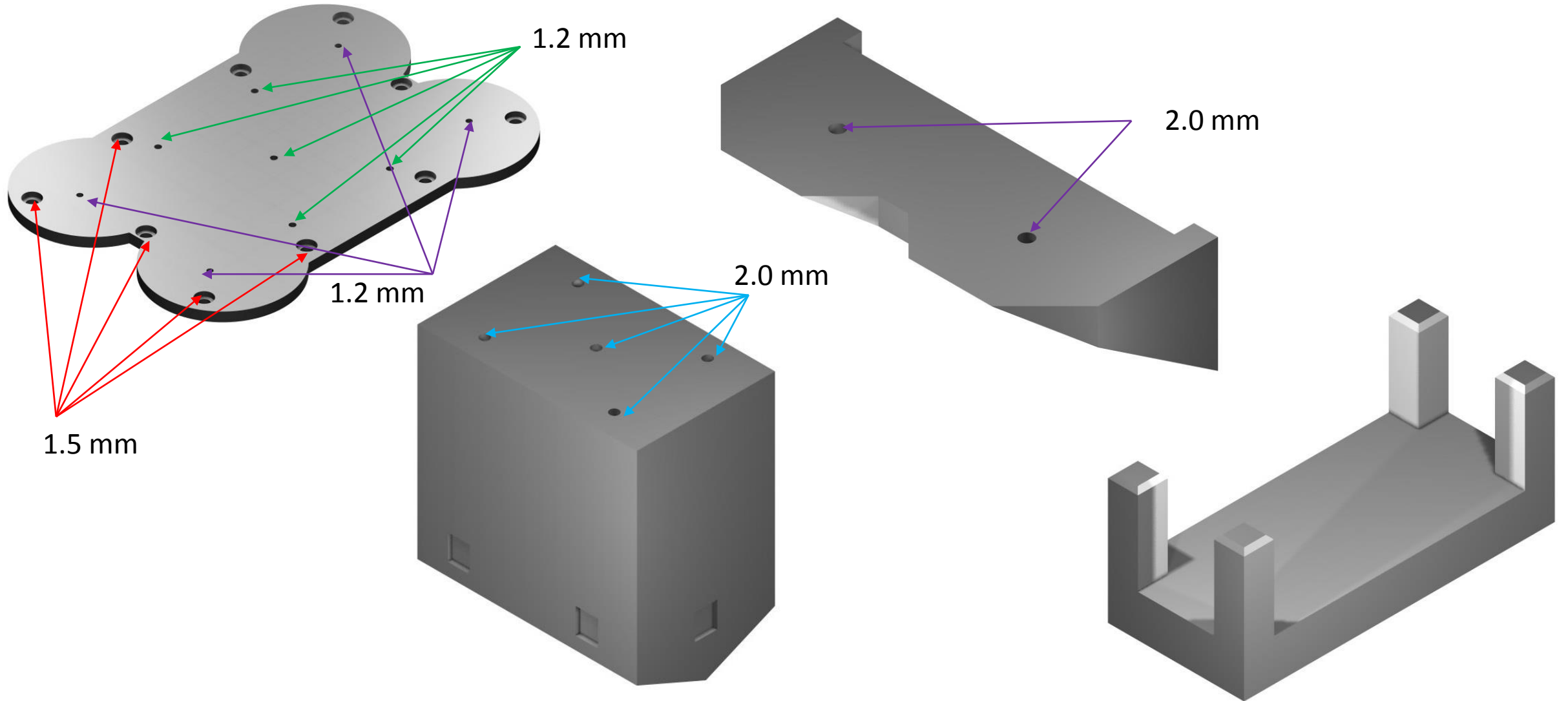

Clean up the 3D parts (4)

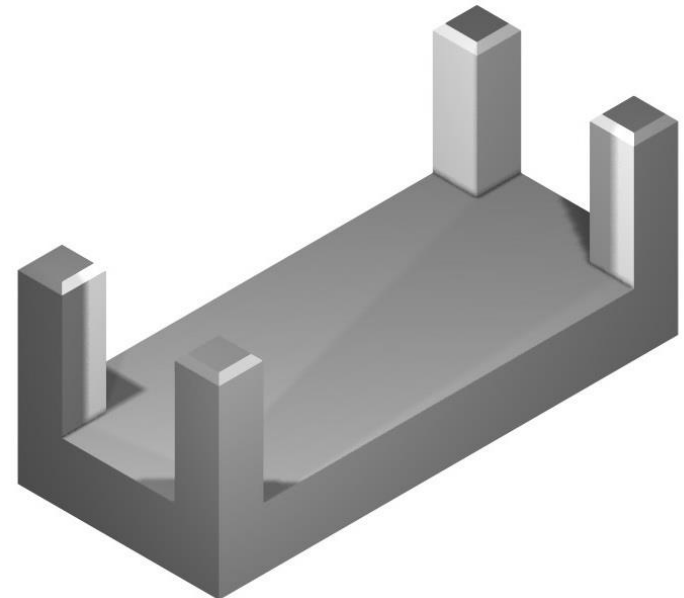
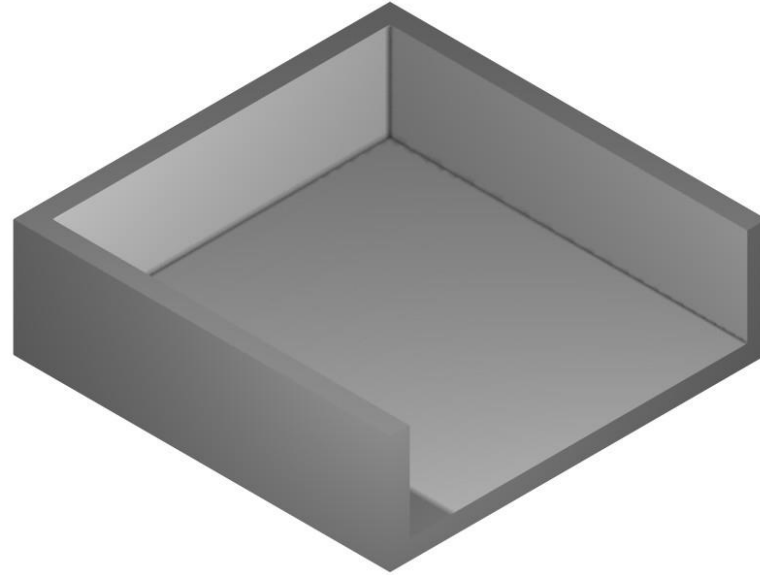
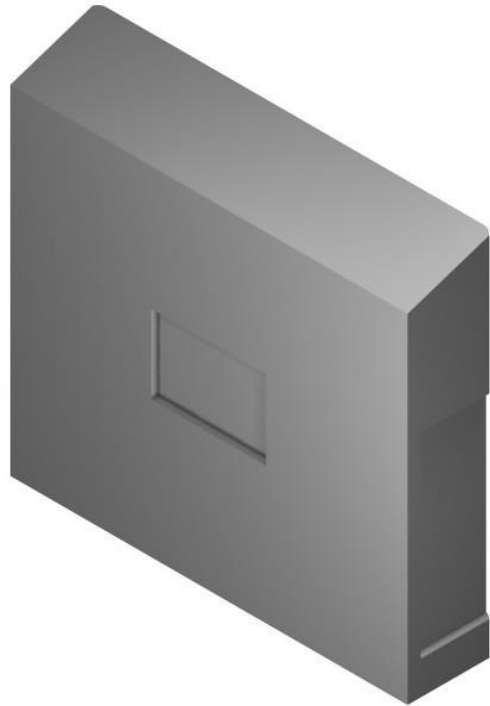
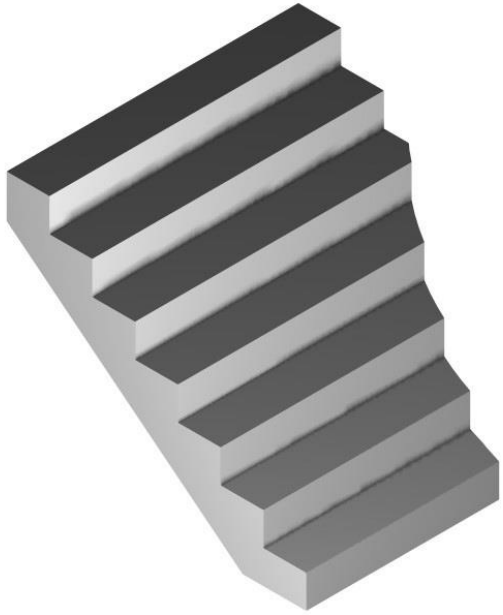

Step 1

Please read the instructions all the way through, no exceptions, and then read them again, so that you understand them. Understanding makes for a better model.

Step 2

This is the base to which the silo is attached.

The base has 4 x ¼ inch “T Nuts” located in such a way so that they do not interfere with the screws securing the silo base.

The “T Nuts” are mounted flush with the top of the timber and ¼ Inch screws and washers (not supplied) are located through your layout, to hold the silo in place. This can be a permanent or temporary mounting. If you need to repair the structure at any time in the future. **“Ensure that the screws are just the correct length as screws that are over length will damage the base of the silo.”**

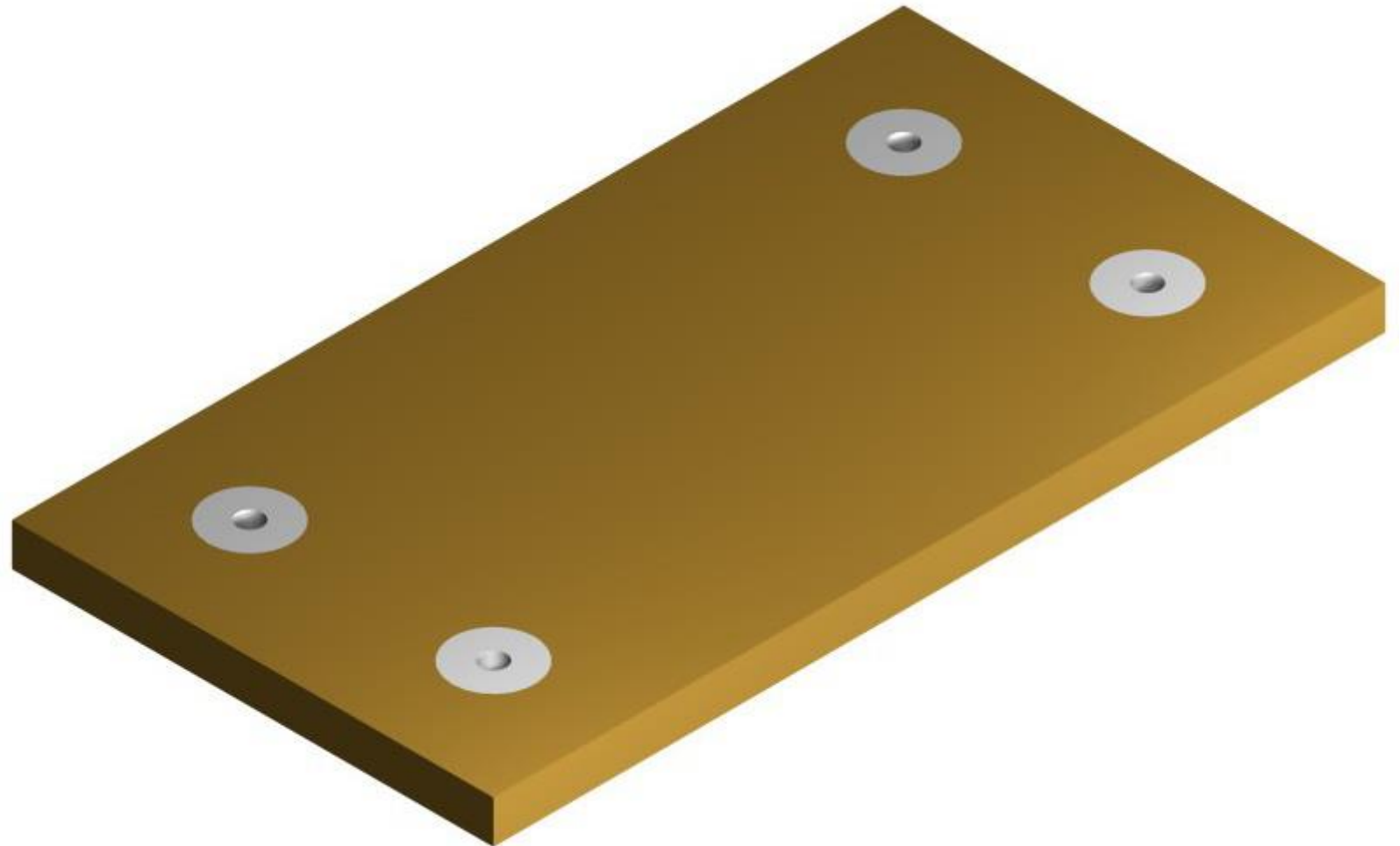

Step 3

Ahh the colour Purple. -----
There is a reason for this and it is a method of understanding the parts that are being worked on. If the part is "Grey" it is the part that **has been** worked on, and if the part is "Purple" it is the part that **is being worked on**, or the newly introduced part for construction purposes.

The "Silo Base" is attached to the "Timber Base". Before locating the silo base to the timber base, clean out all the holes with a 1.5 mm drill for the 6 holes within the drainage area, and 2 mm drill for the 5 larger holes that are rebated.

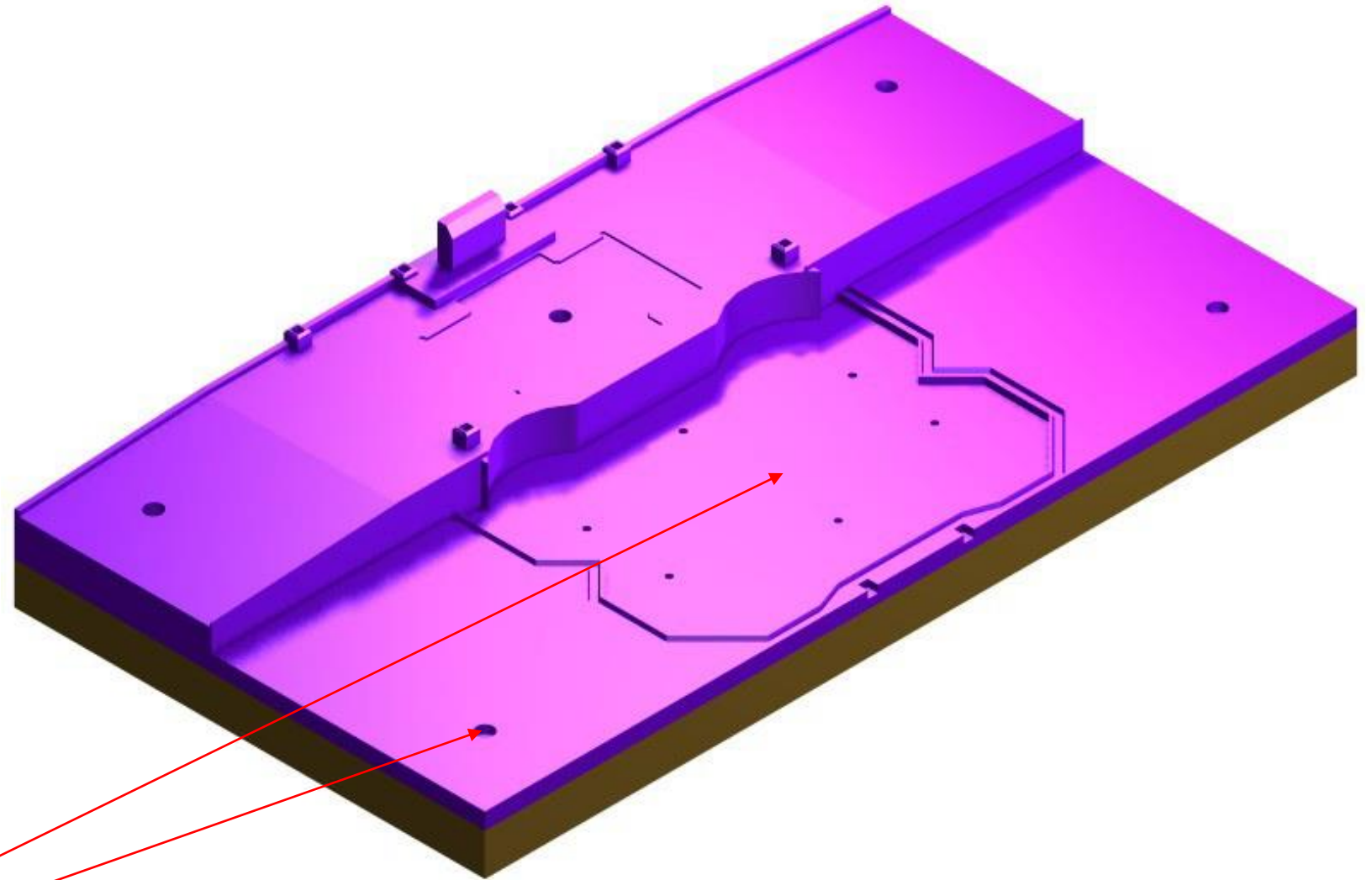

Step 4

Locate the silo base onto the Timber base, and mark the location of the 5 holes indicated with screws (purple). Clamp the base to the timber, using soft type clamps or Bull Dog Clips (not supplied). Drill small pilot holes into the **timber base**, to a depth of 5 mm, using a 1.2 mm drill, for the holes indicated with the purple screws. This will allow a small pilot hole for the screws to bite into the timber. Glue can also be used as an insurance against the base coming away from the timber. Do the same with the smaller holes within the drainage area (**only in the timber base**) using a 1.5 mm drill, again to a depth of 3 mm just to provide a hole for the screw to clear.

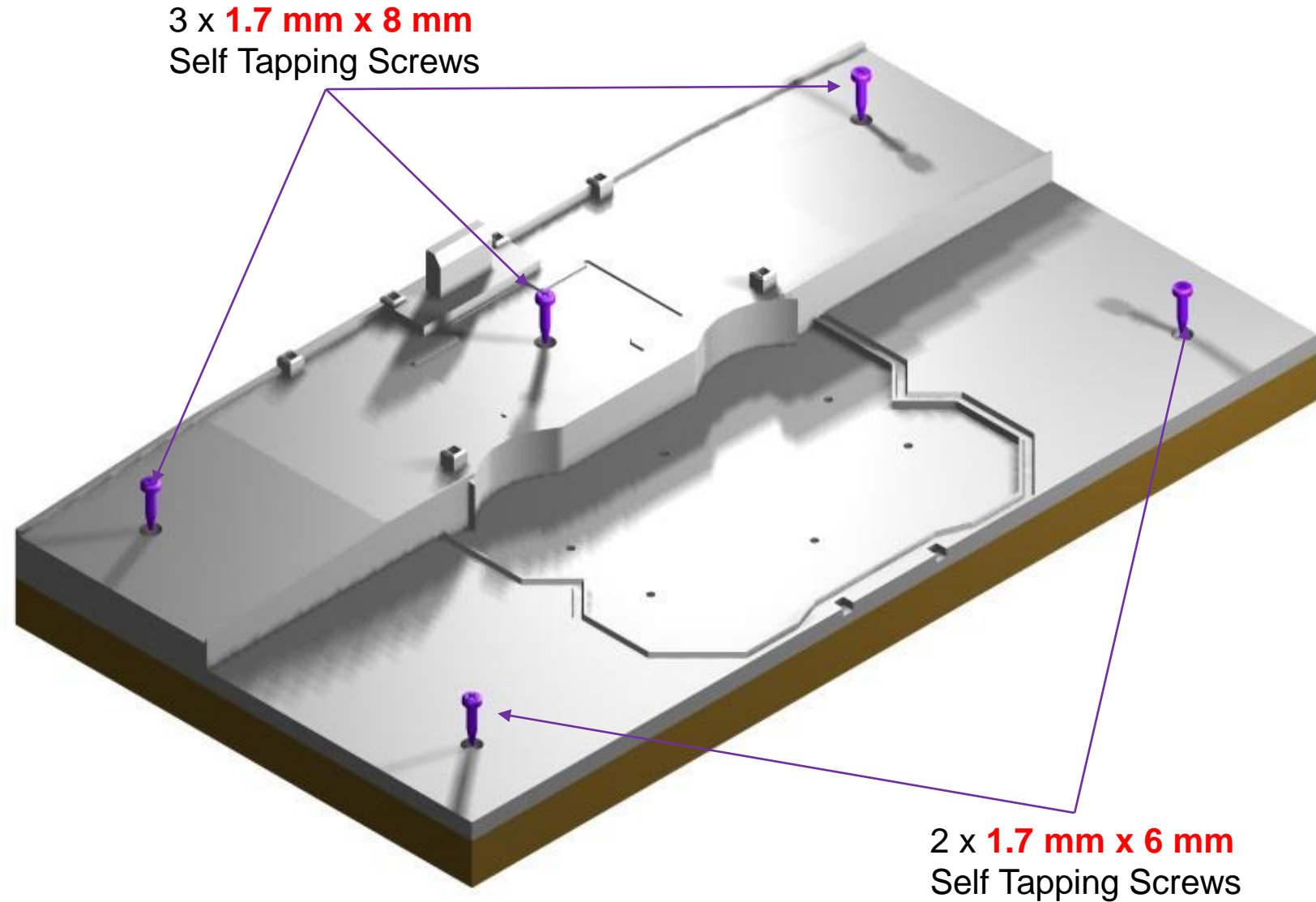

Step 5

The silo workhouse, is 3D printed and can be slightly rough. If YOU think it is excessively rough, the time has come to sand the workhouse to a level of smoothness that “YOU” are happy with. Firstly undercoat the structure, so that the texture shows through. And using wet and dry paper, sand the workhouse, starting with course paper, working up to a finer paper only stopping when **“YOU”** are happy with the result. This is your silo, you need to be happy with the way it looks. But now is the time to work this part to your level of finish.



Step 6

The base of the workhouse, is designed to clip into the silo base, and fit neatly within the drainage edge.

The rear of the silo has a couple of small sections that need to be well trimmed to fit into the base. Please ensure that the workhouse fits nicely so that it should be tight enough so the weight of the base can be supported by you holding the workhouse. The workhouse is to be screwed into the base using 6 x **1.7 mm screws x 8 mm** long. Again ensure that there are pilot holes that have been drilled into the timber base, as previously stated.

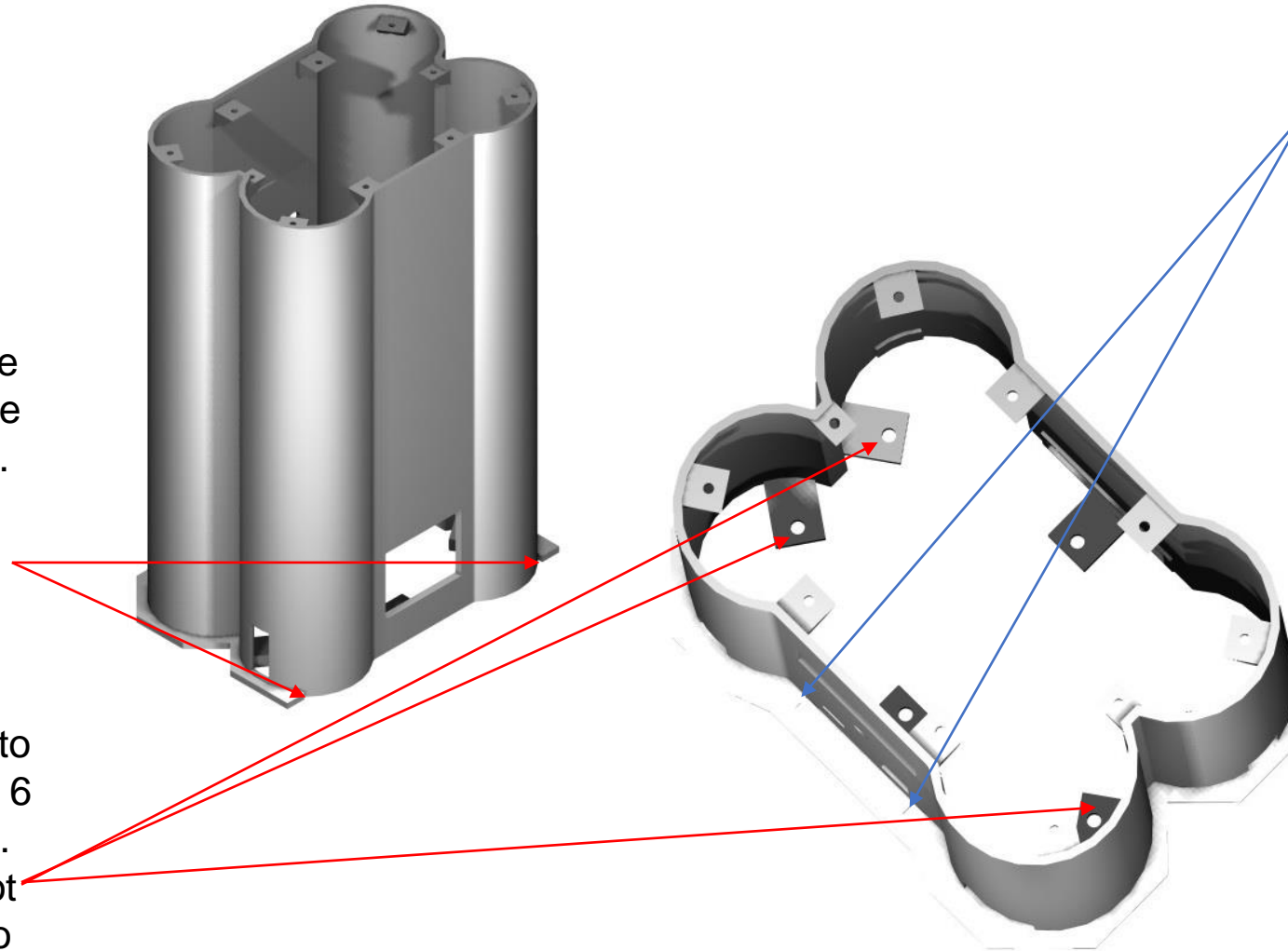

Just a note:

ensure that the holes for the Outloading Platform, just at the base of the front wall, have been expanded with a square file to allow the platform to fit easily, you can do the same on the outer holes, test fit the platform before final fitting.

Just a suggestion. ---- Obtain a set of long thin screwdrivers to allow you to locate the heads of the screws in this operation, they can be obtained at most good hardware stores. You can get a set from Bunnings or Amazon online. ----- Best Choice 9-Piece Precision Screwdriver Set | Phillips, Flat and Torx Star.

Step 7

The Cupola base is fitted into the top of the work house, and secured around the perimeter, with screws. This does a few things, it secures reinforces the work house, while giving a platform for securing the cupola and the bin roofs.

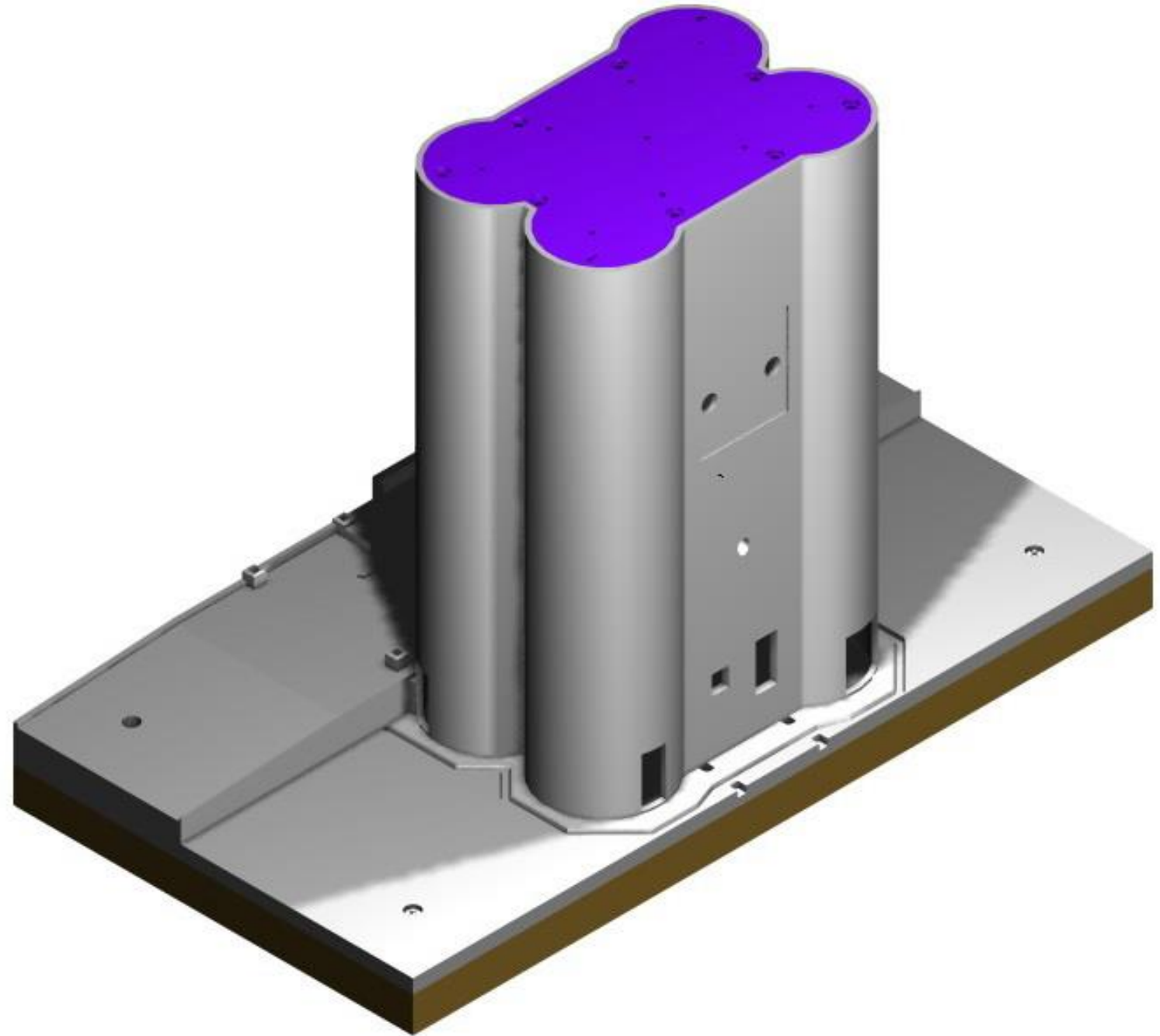

Step 8

The Top is secured with 10 x **1.4 x 6** mm long self tapping screws. When screwing them down, do not use excessive force as the plastic will strip, just nip them down so that the top sits flush with the work house. When tight just give the silo top a slight rub with fine wet and dry to remove any irregularities and bumps. If you do strip any of the holes, use larger screws to temporarily home the top in place and apply glue to hold the top into position and remove the screws when dry.

10 x **1.4 x 6**mm long self tapping screws.

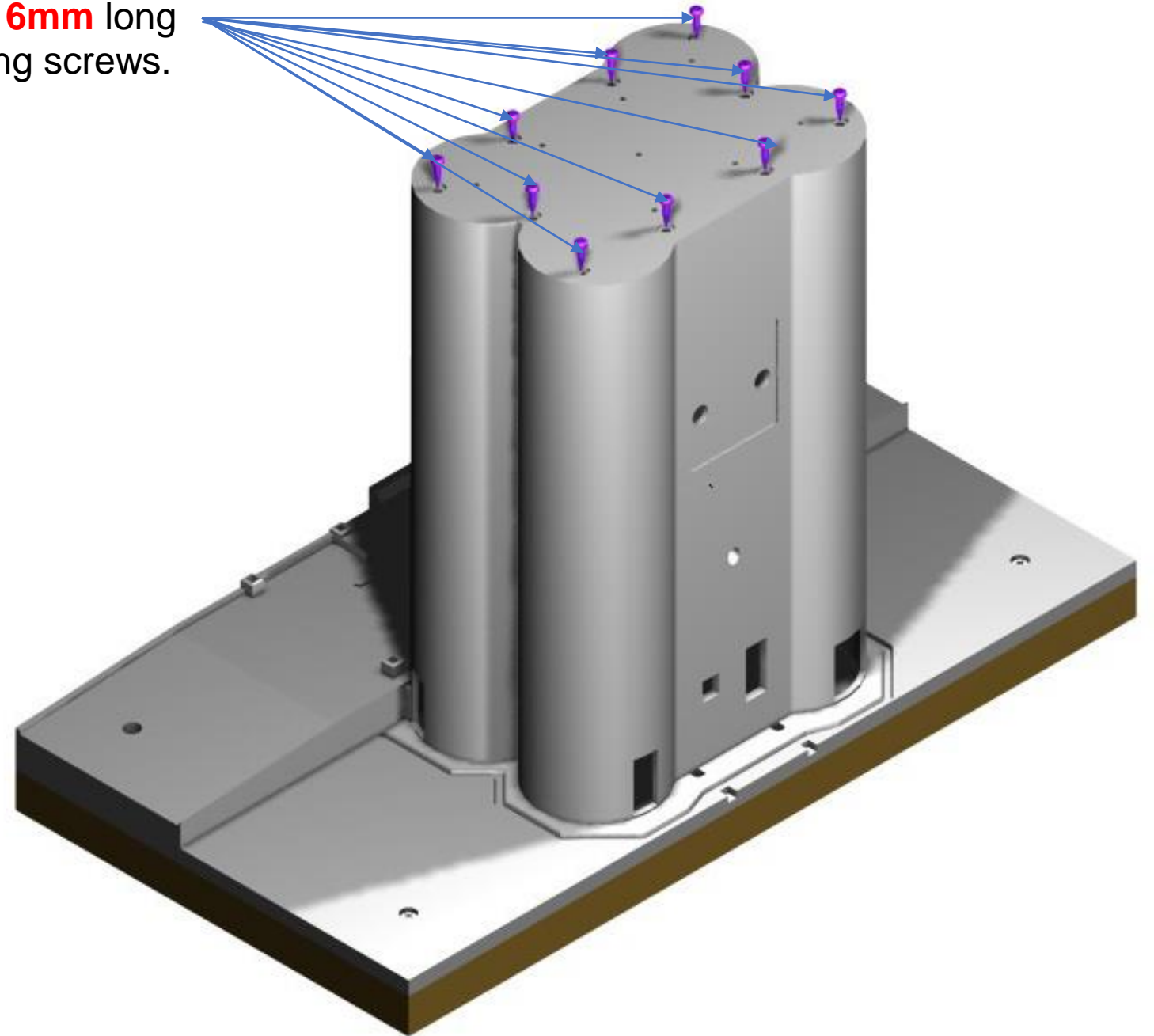

Step 9

The cupola is fitted next. The cupola looks symmetrical however it is **NOT**. The windows closest to the side should be located on the rail side of the silo. The cupola is also screwed into the cupola base, and again the screws need to be fitted gently, so as not to strip the plastic. Use **1.4 mm x 8 mm** screws

5 x **1.4 x 8 mm** long self tapping screws

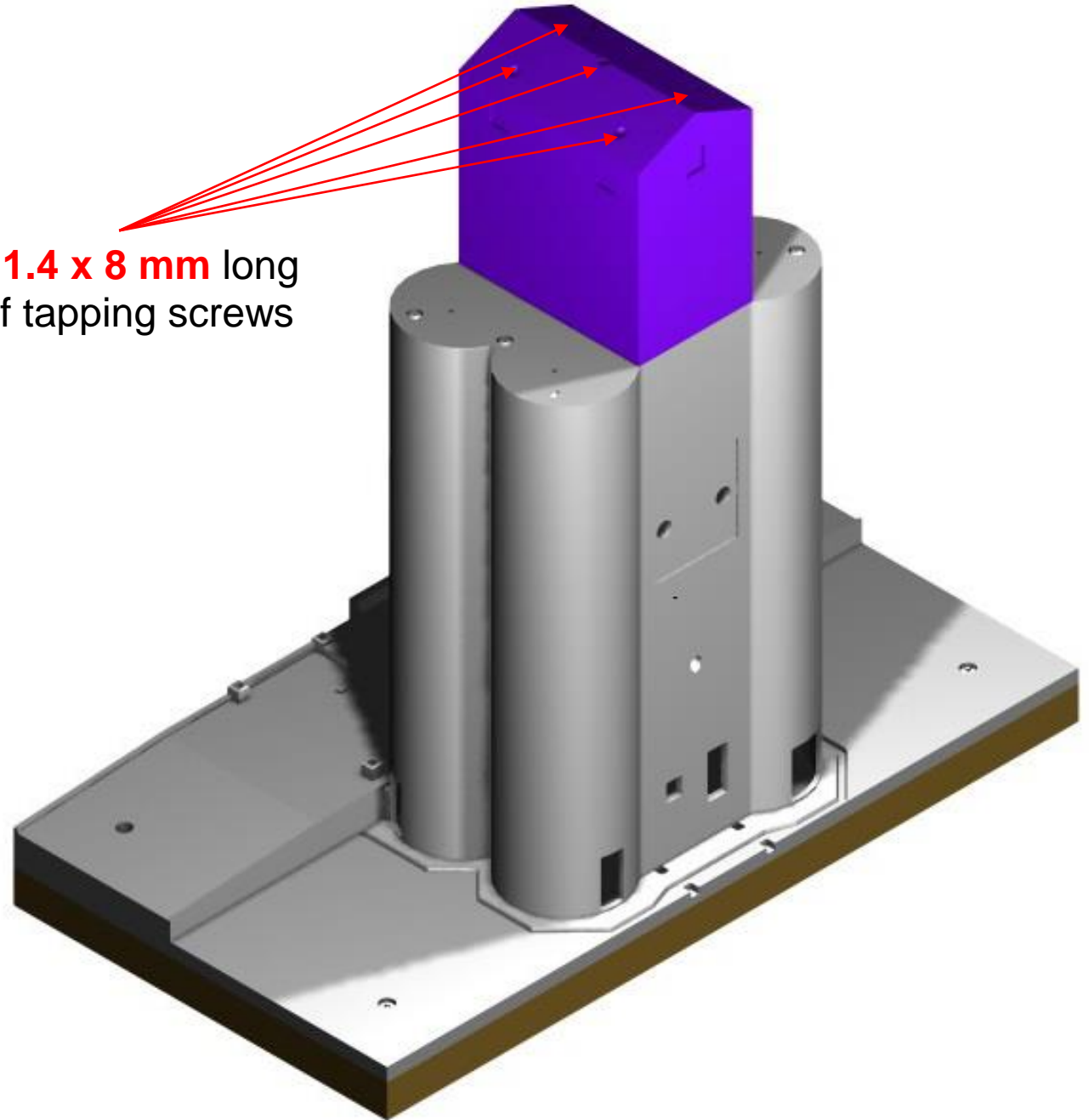

Step 10

The Bin Roof is fitted next. There are 2 roofs, and they are exactly the same. These are also screwed into the cupola base plate previously fitted, using 4 x **1.7 mm x 8 mm** screws. 2 one side 2 on the other

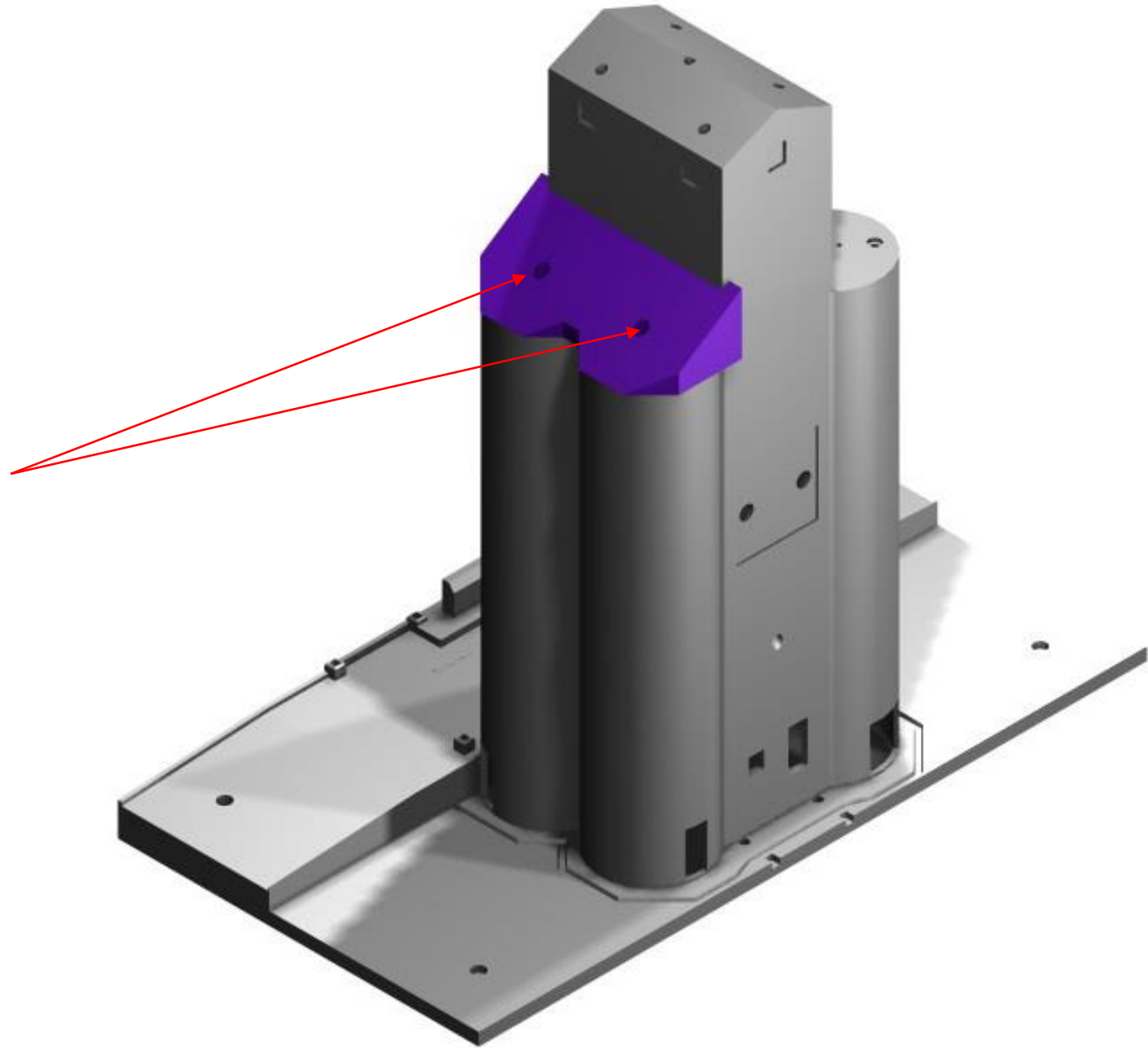

Step 11

The basic structure is now complete. It is now time to cut the corrugated cladding from the sheet of Evergreen 2020 car siding. I have to thank Ross Balderston for recommending this product, as I have previously asked him what he uses for his magnificent N Scale Models. This was what he suggested.

Warning..... So that you do not waste material, the red arrows to the right show the way the corrugations in the styrene should run, and the setup of the pieces is done to accommodate this. In this kit, I have provided 2 copies of the drawings just in case the modeller buggers up the first one, and needs another drawing. (experience speaking)

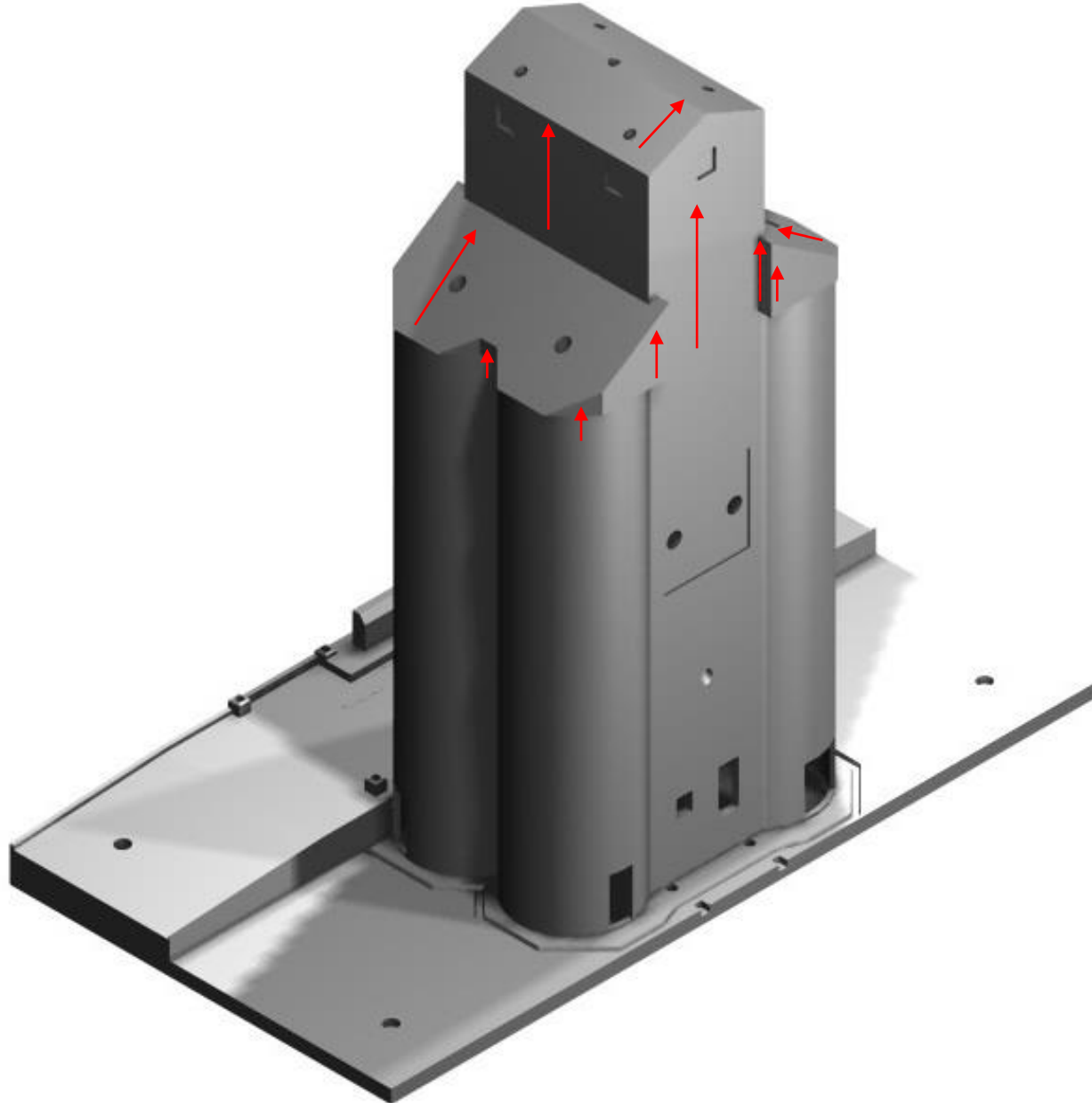

Step 12

The kit is supplied with a sheet of Evergreen 2020 scribed styrene, this is used for the cladding of the Silo Roof, Annex and Wagon Shed. To assist in this task, there are two printed paper templates provided. (one is a back up) This template is glued to the “**BACK**” of the styrene sheet (using a repositioning adhesive). Ensure that the lines are square to the edge of the styrene sheet. The shapes are cut out using a sharp hobby knife and steel rule (**TAKE YOUR TIME** ---- Light cuts to start with and heavier as you get through the styrene, the styrene is only 0.5 mm thick, so light cuts are preferred). The part shapes are orientated the correct way to get the most out of the sheet of styrene. If you make a mistake, you do have more styrene to get you out of trouble. The image opposite, shows the parts required for the job. Any part that overhangs the bins, should do so by 0.5 - 0.75 mm, but keep the distance consistent.

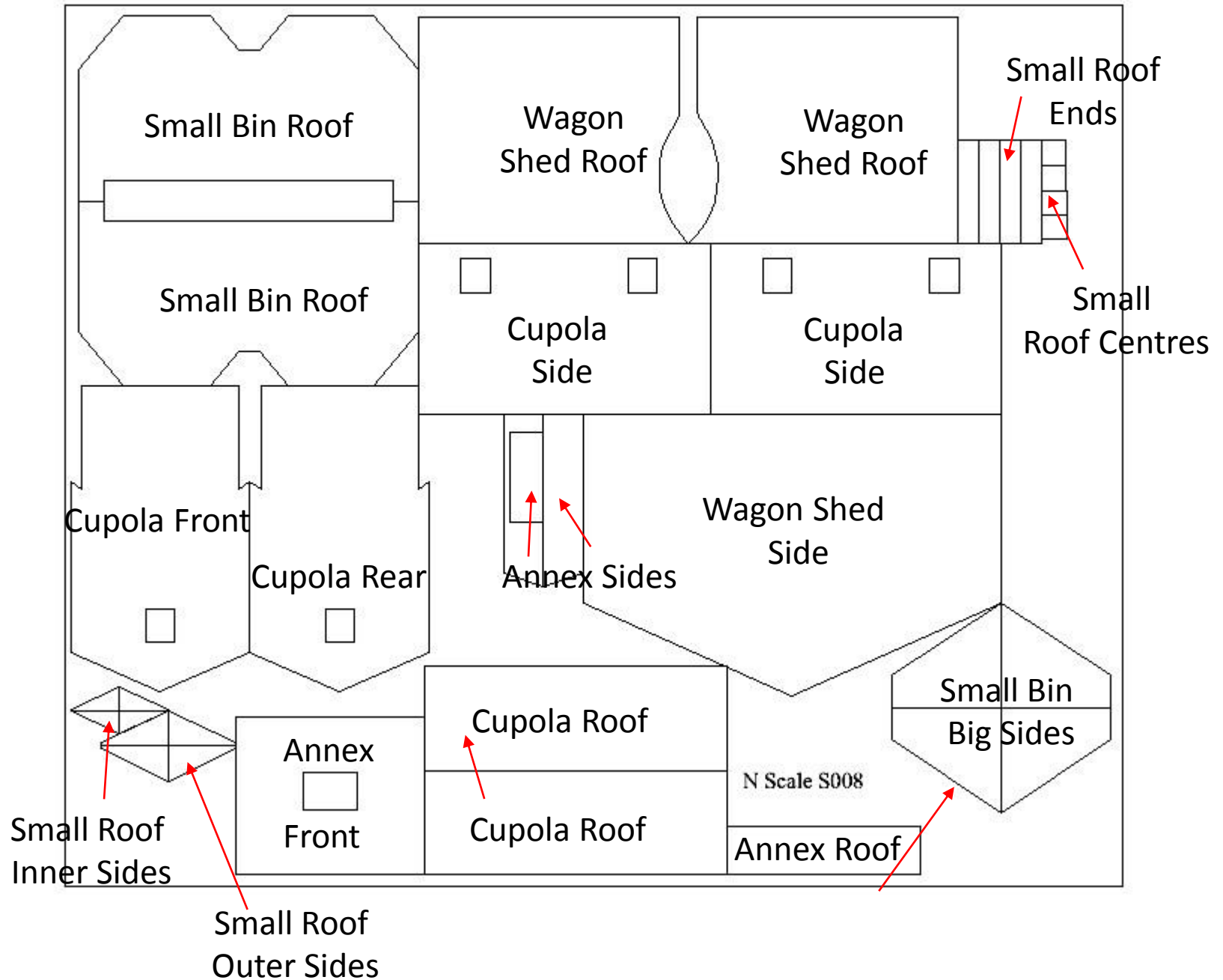

Step 13

At this stage you can start the process of cladding the cupola and roof sections of the silo. There is Evergreen 2020 supplied with the kit and you can cut and glue this to the roof section. This should be done so that all the edges are straight and square with the corrugations of the styrene.

Holes need to be cut into the cladding where the windows are located to accommodate the 3D windows. The windows have been designed to fit inside the cut outs in the 3D printed silo parts. Hopefully, we can now walk through that process. The 2020 styrene should be glued to the silo workhouse. A gel slow set supa glue is the best option for this.

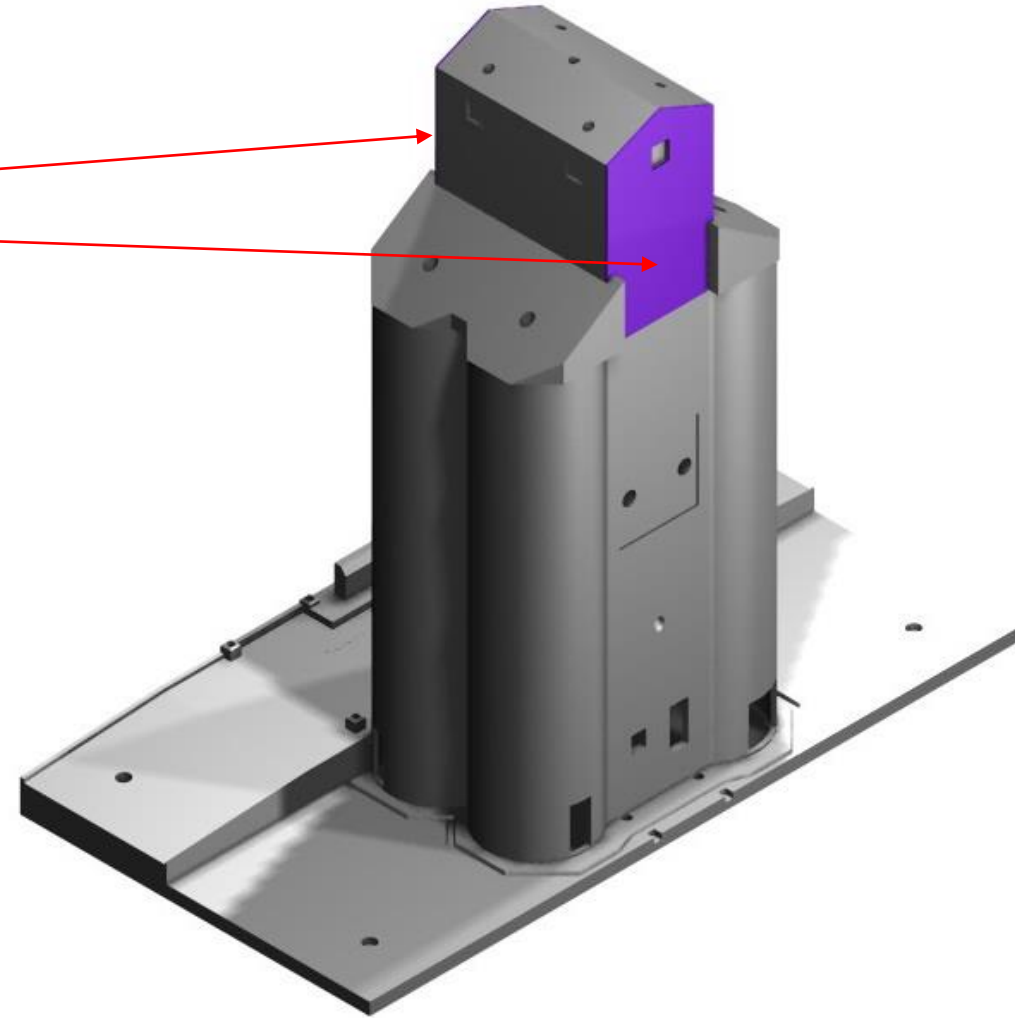
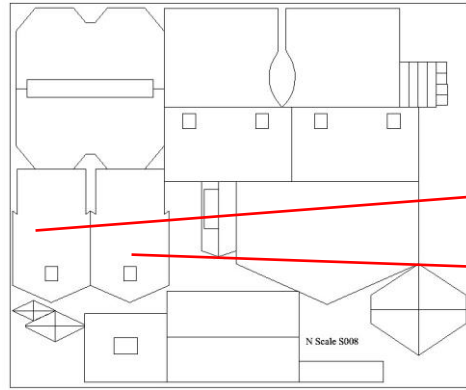

Tips: The dimensions should result in slightly oversize parts which will require trimming. The sides edges can be filled at 45 degrees to the side they fit against, this is not absolutely necessary, but it would make for a better joint. Take your time with this process and avoid the overuse of glue, and you should achieve a great result.

Step 14

Once the front and rear face of the cupola are clad, we can move on the small parts under the sloped roof of the workhouse. The starting point for this is the centre of the roof on one side. The small rectangular piece, fits in the middle and has an overhang below the bin top of between 0.5 and 0.75 mm. This line should be maintained by all parts that sit below the bin top mark. These parts are very fiddly, and time needs to be taken to ensure that they are fitted correctly. Both sides of the silo need to be fitted.

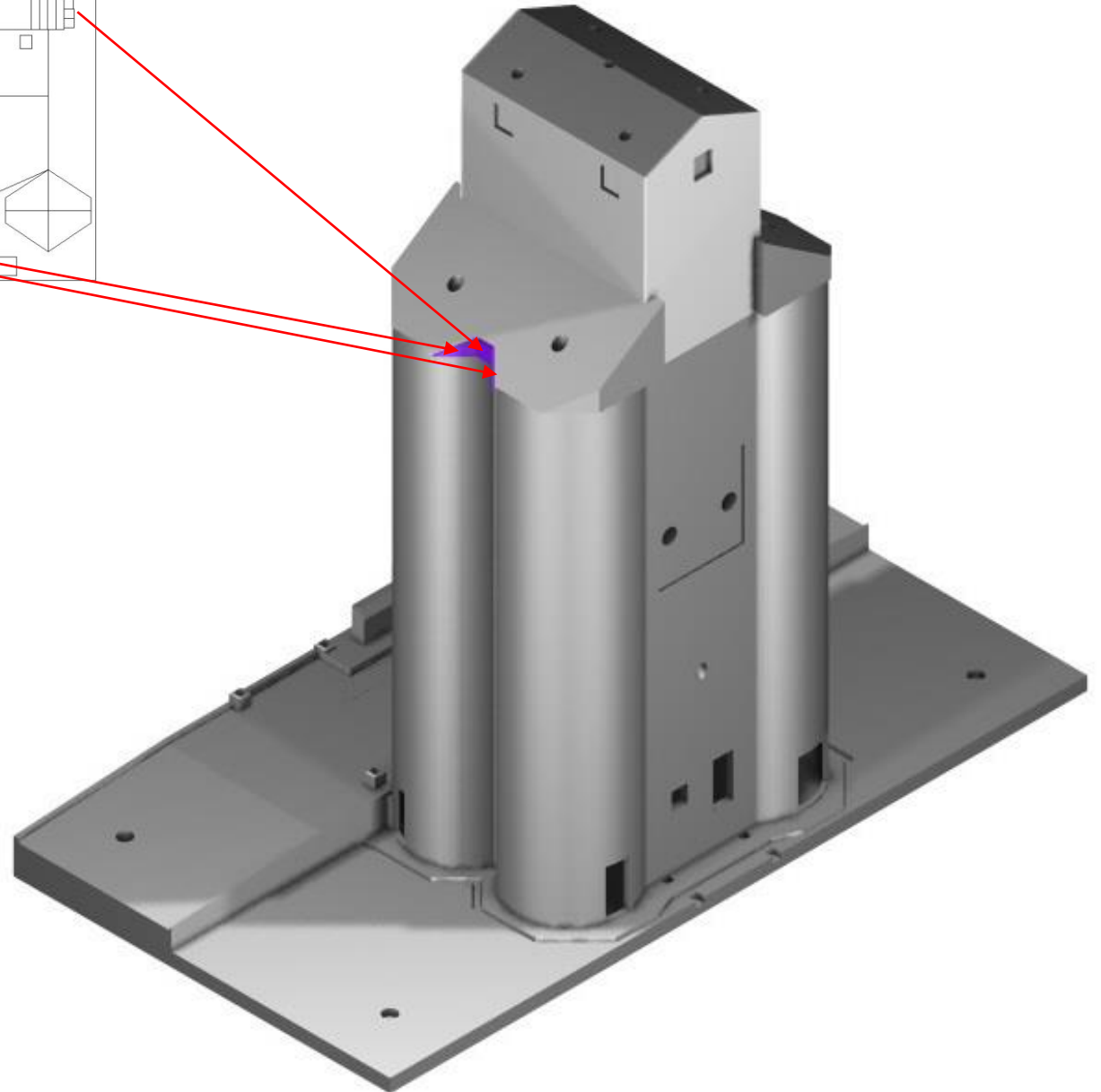

Step 15

The next cladding pieces to be attached to the silo are the Bin roof outer sheets. These pieces need to be trimmed with fine sandpaper. They all need to be 0.5 and 0.75 mm below the bin top mark. Start with the Red Arrow piece and ensure that it sits flush with the outer edge of the bin roof. The Green Arrowed piece goes next and the back edge sits flush with the red arrowed piece. And finally the small piece at the front (Orange Arrow) fits next. Once the glue is dried sand the tops so that they are flush with the bin roof and sand the edge joints to ensure no overhang between pieces.

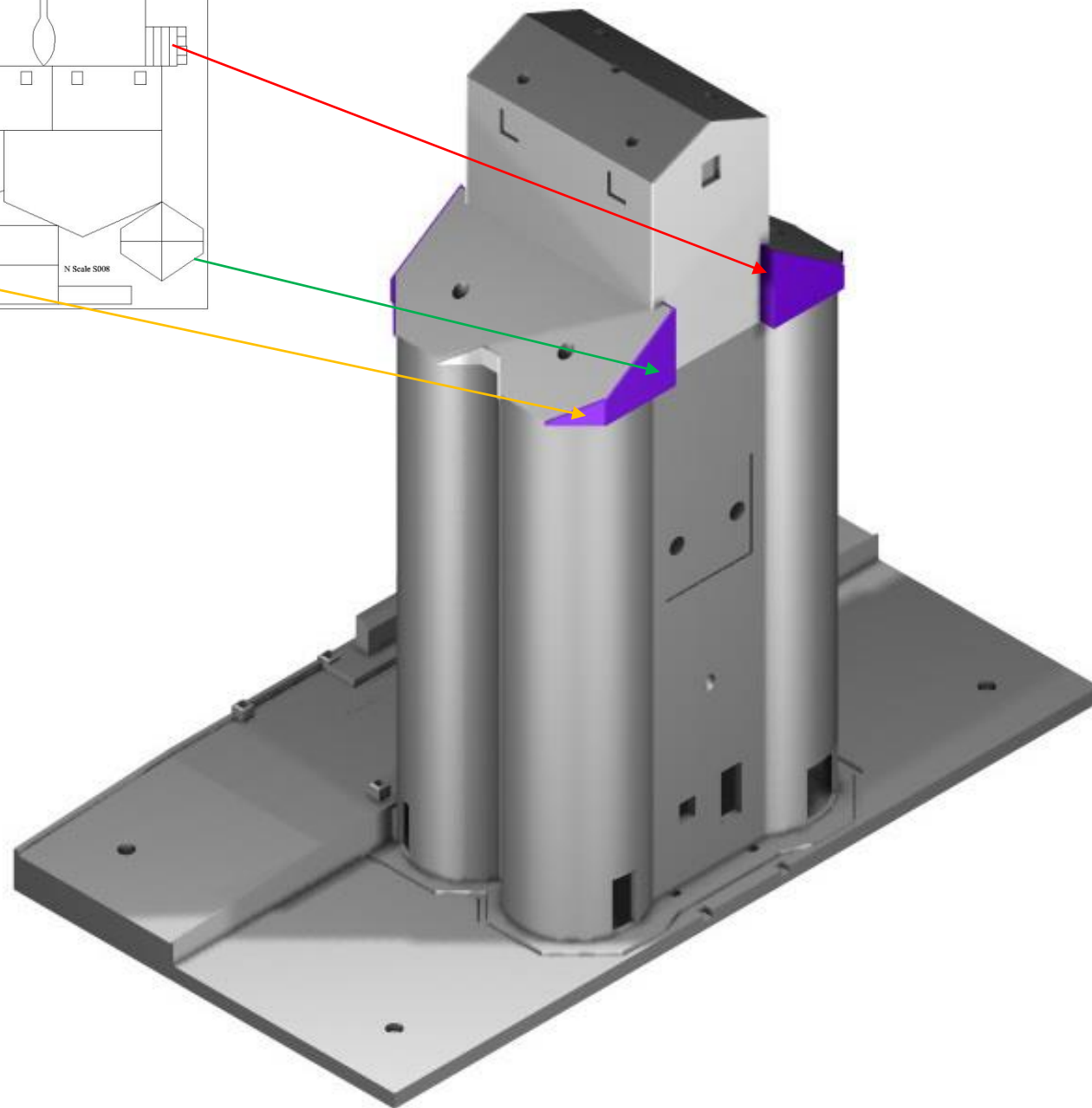
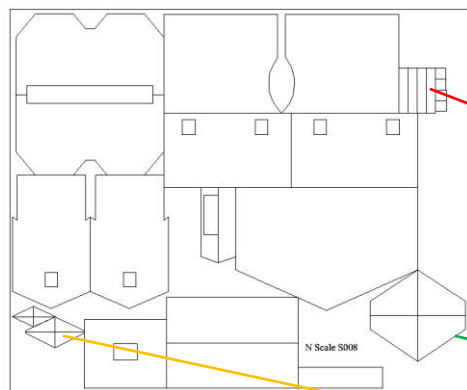

Step 16

The bin roofs are fitted next and they may need trimming on the inside edges for a neat fit. They should have approximately a 0.5 mm overhang. Try and keep them square when sanding the edges. A very thin piece of masking tape can be used to simulate the flashing, on top of the bin roof covering. The flashing goes all the way around the bin roof and even to the small top sections on the sides.

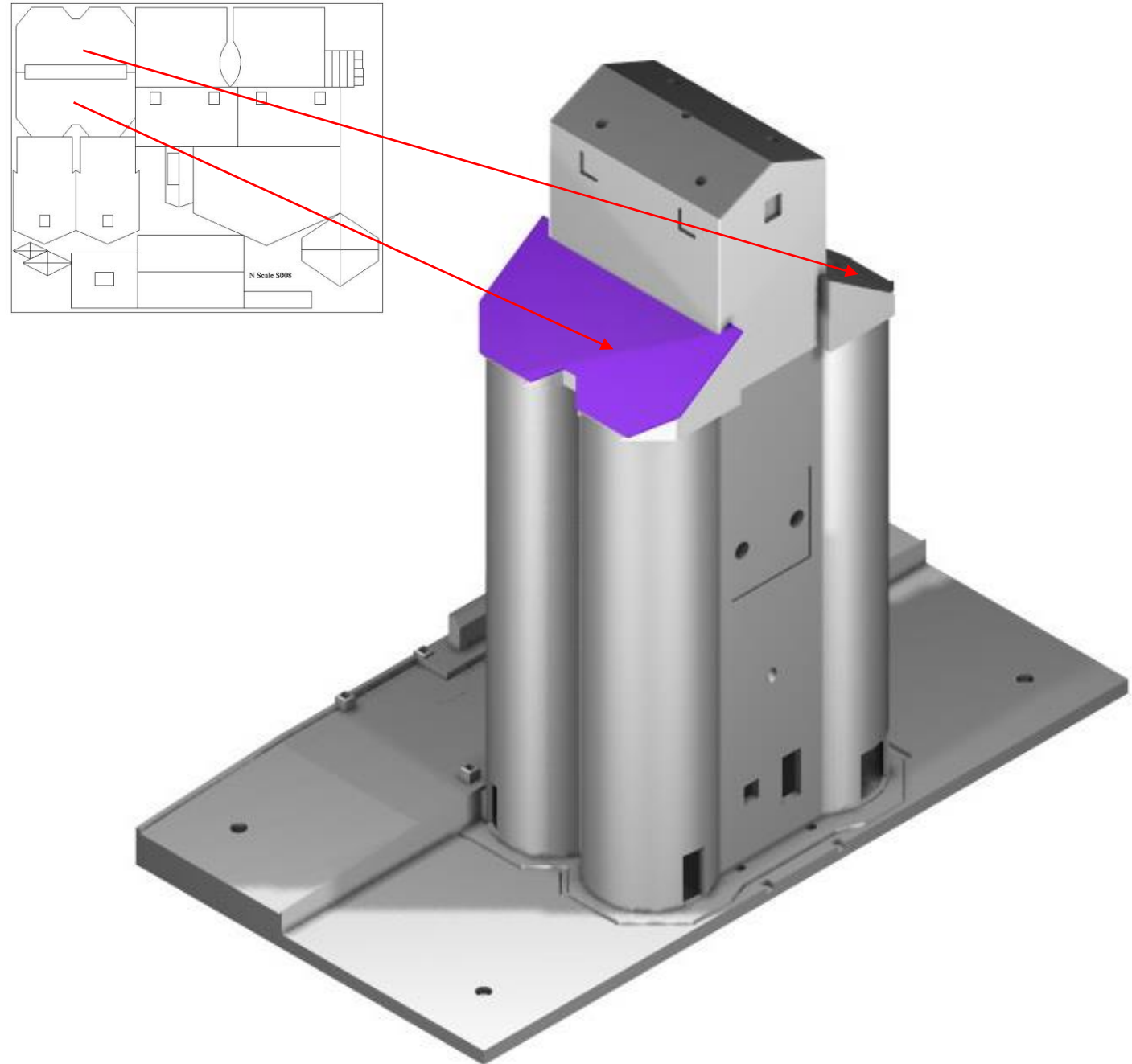

Step 17

The cupola sides are next and these are orientated so that the window is closer to the edge on the track side of the silo (front). Again the part will require gentle sanding to clean up the edges. These face pieces fit over any flashing fitted to the bin roofs.

The image above is looking from the back of the sheet, (the paper side).

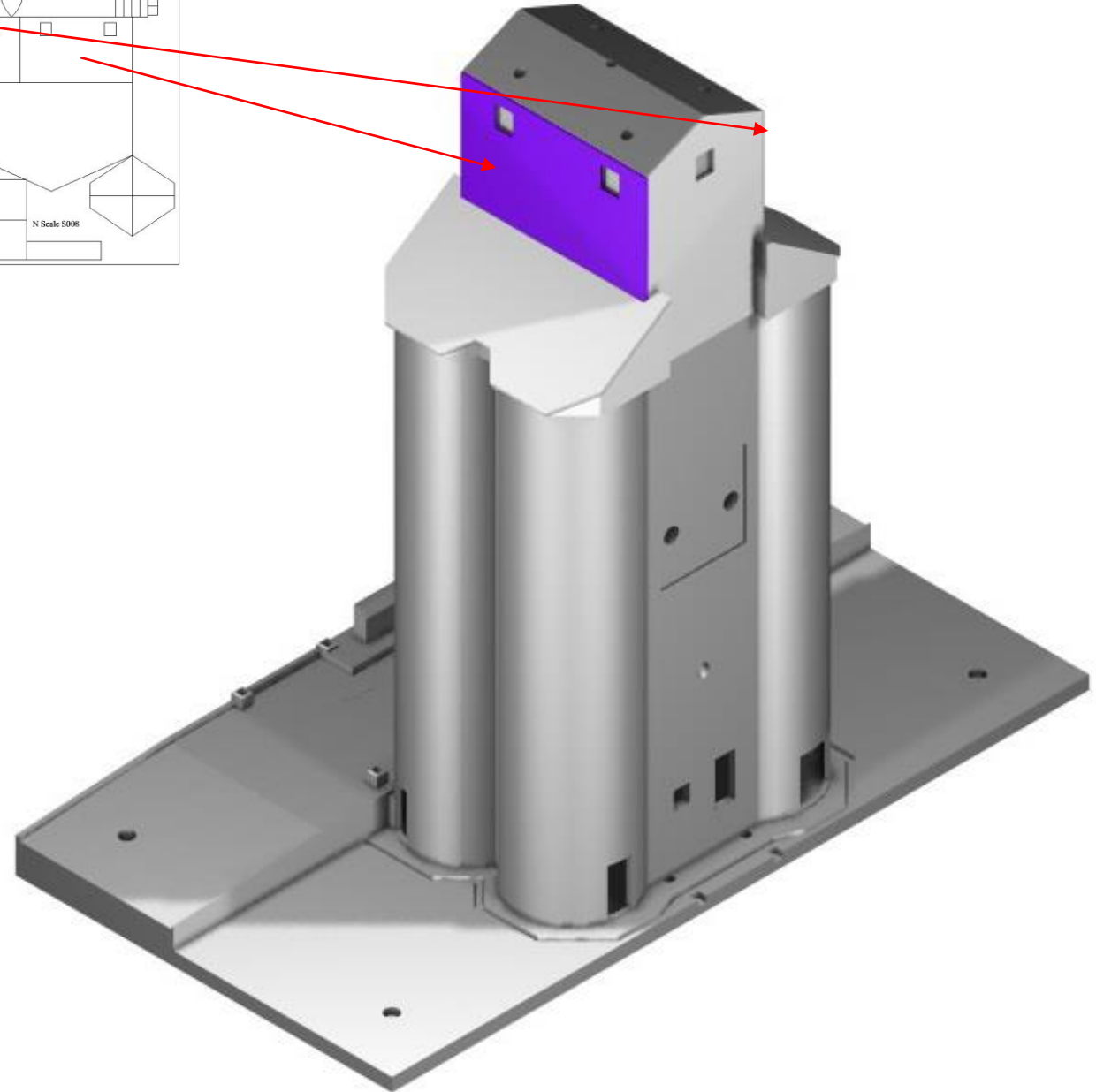
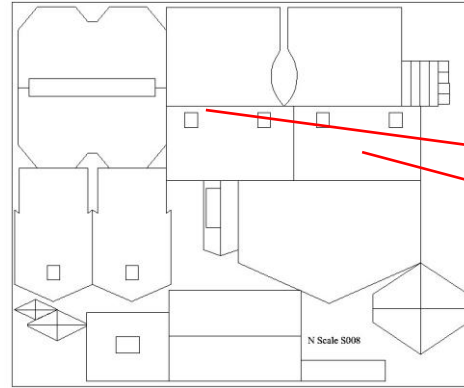

Step 18

The cupola roof is fixed in place. Make sure that you centre the roof panels, by using a scrape of corrugated plastic to gauge the overhang. To make the ridge capping run a length of the styrene rod and 2 strips of thin styrene (supplied) and glue together.

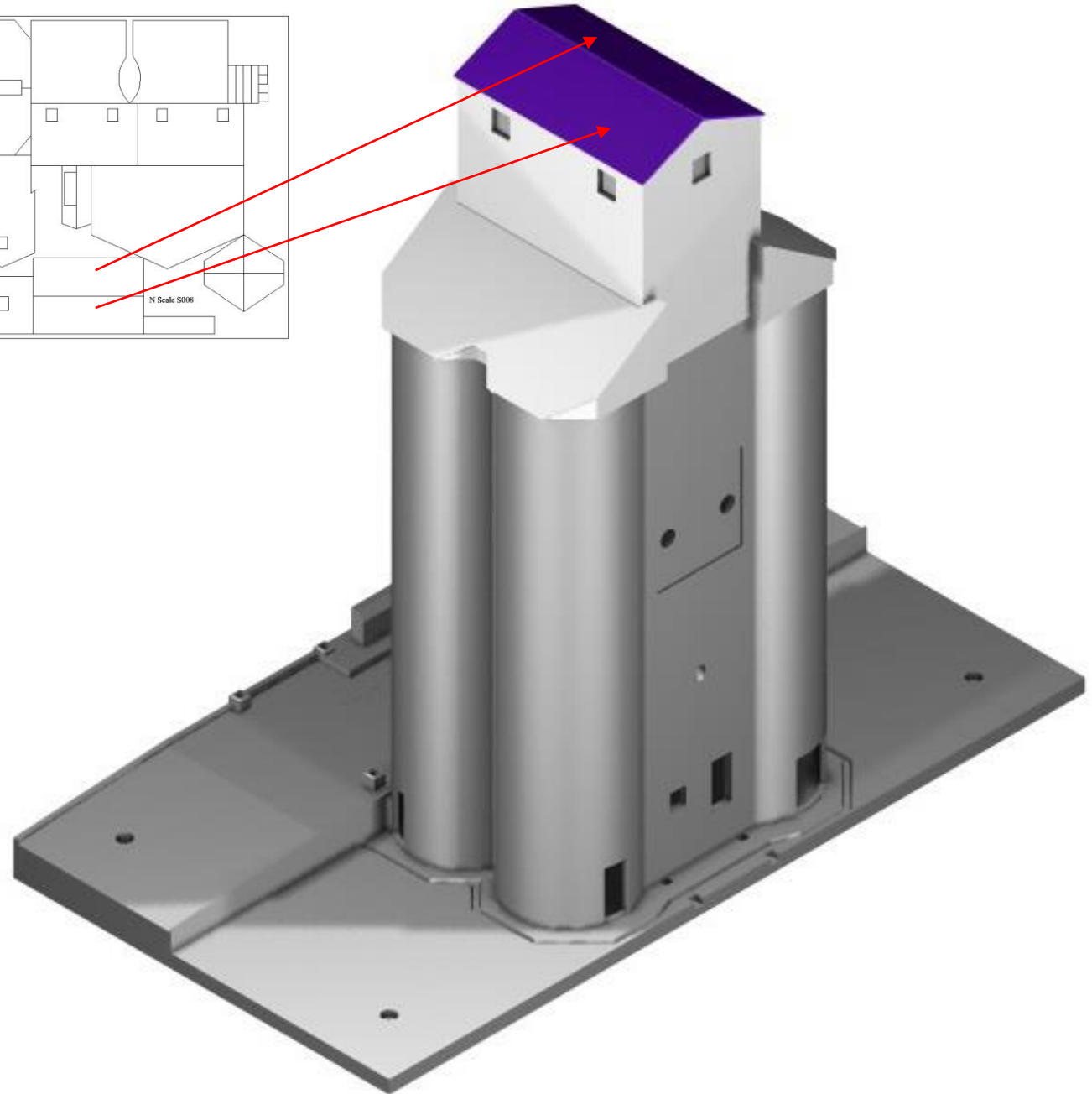
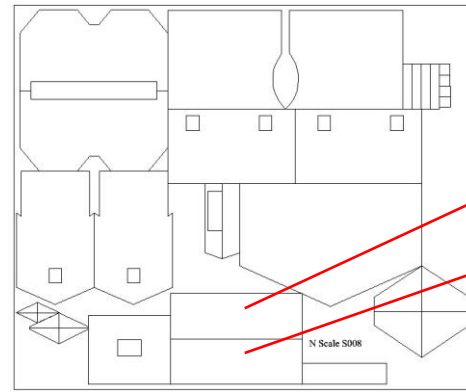

Step 19

The Annex is now test fitted. There are 2 holes in the Workhouse that the Annex slips into. If tight, open up the holes slightly, but ensure that it is not too loose. If it does become loose, double sided tape, can be used to secure the annex to the front wall.

At the base of the Annex there is a 3D channel that needs to be glued into the base. There are 2 small dimples that have to be drilled using a 0.4 mm drill, then glue a small piece of 0.3 mm wire that forms a small hook. The hook is the location for a small length of a flexible cable that is the cable that winches up the out loading chute.

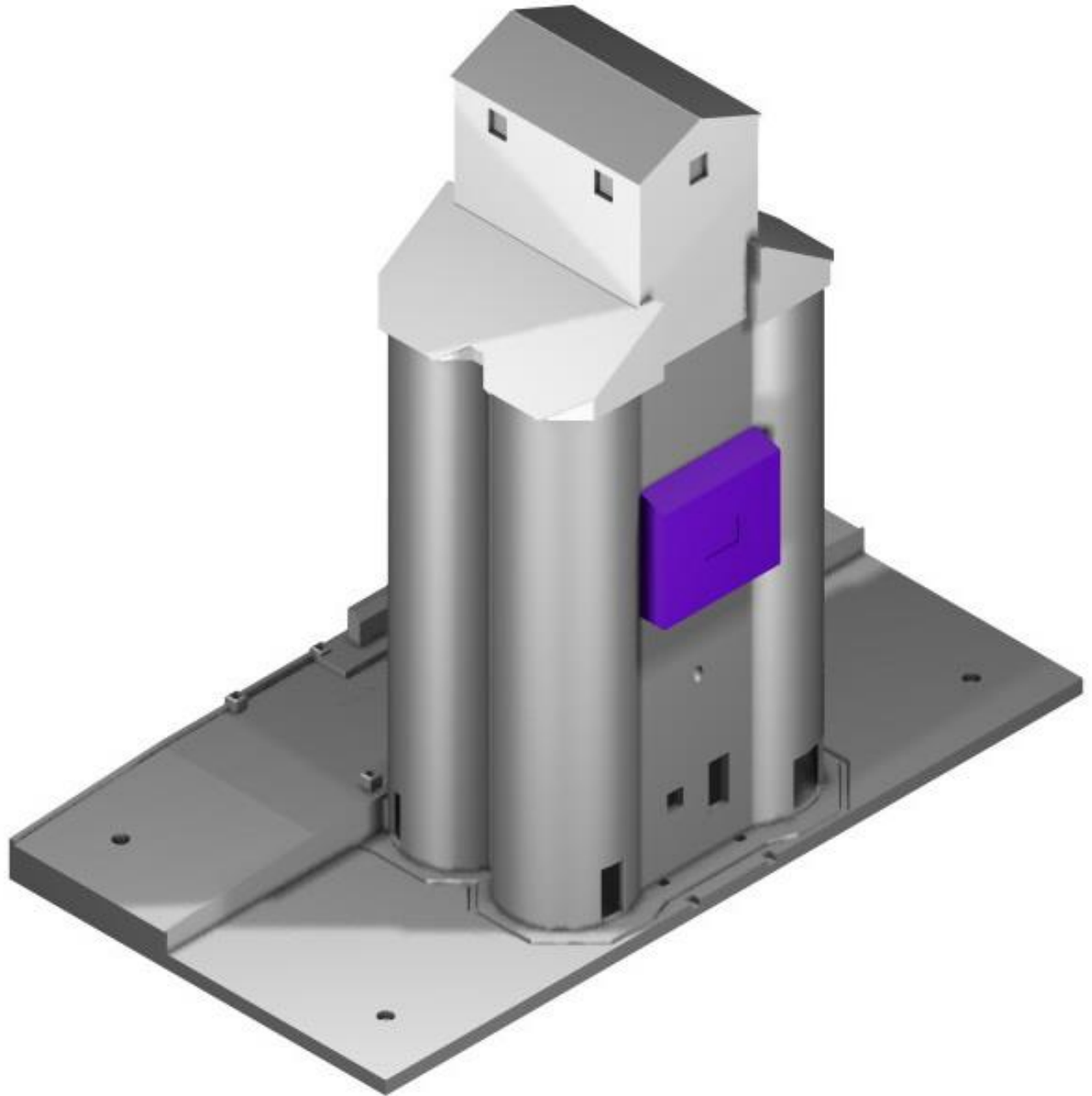

Step 20

The Annex now has to be clad, with styrene. The first part fitted is the left side. The back will need to be trimmed, once the glue has dried.

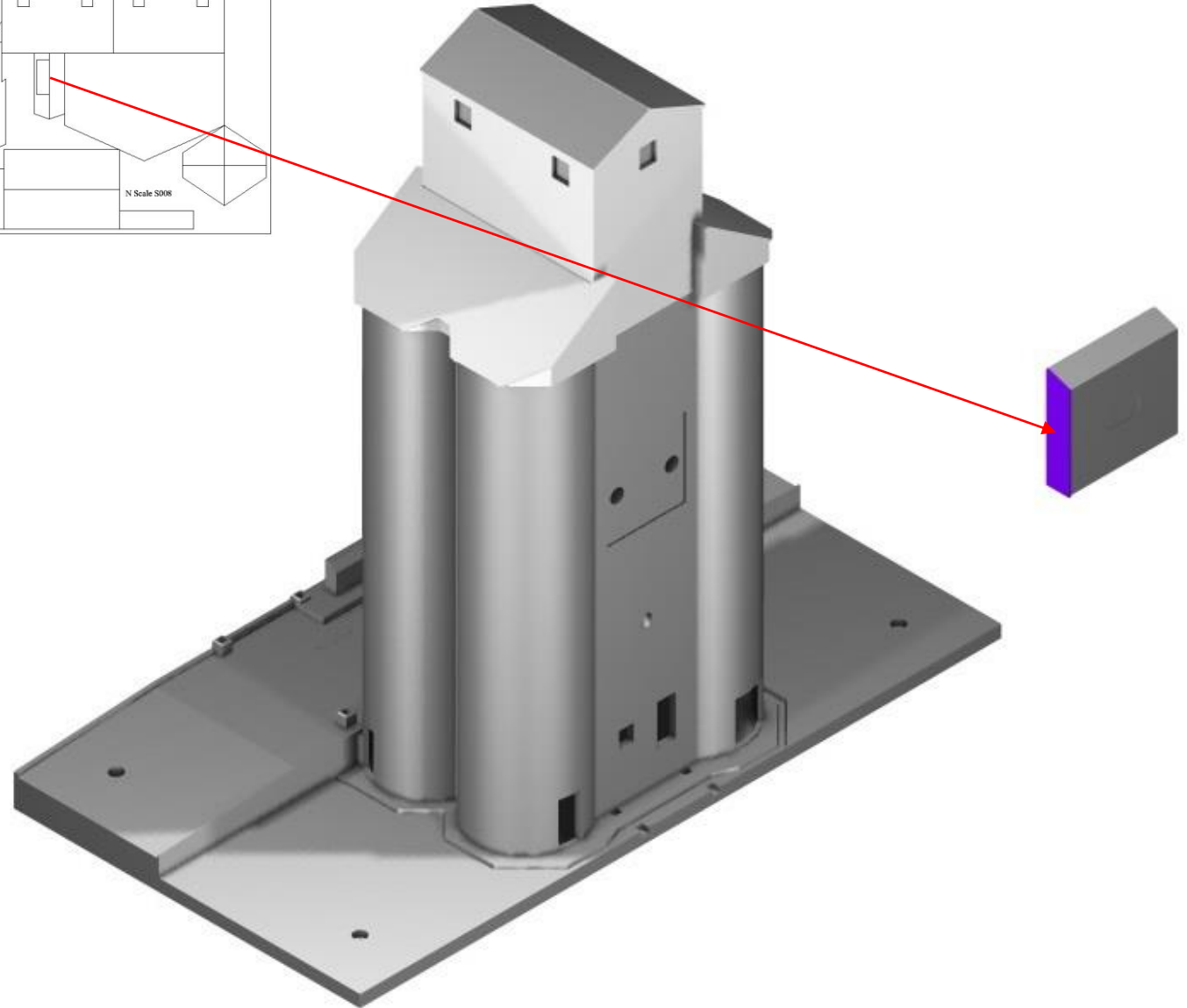
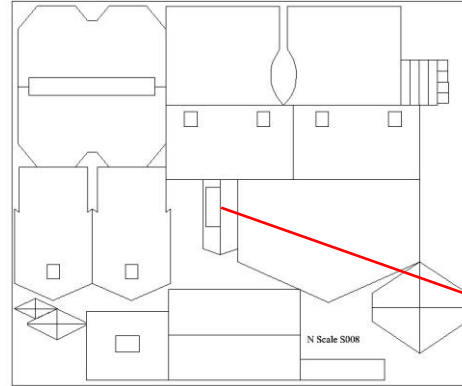

Step 21

Next fit the right side and please be careful cutting the part out as there is a very thin section that can easily break. The back will need to be trimmed, but only after the glue has dried.

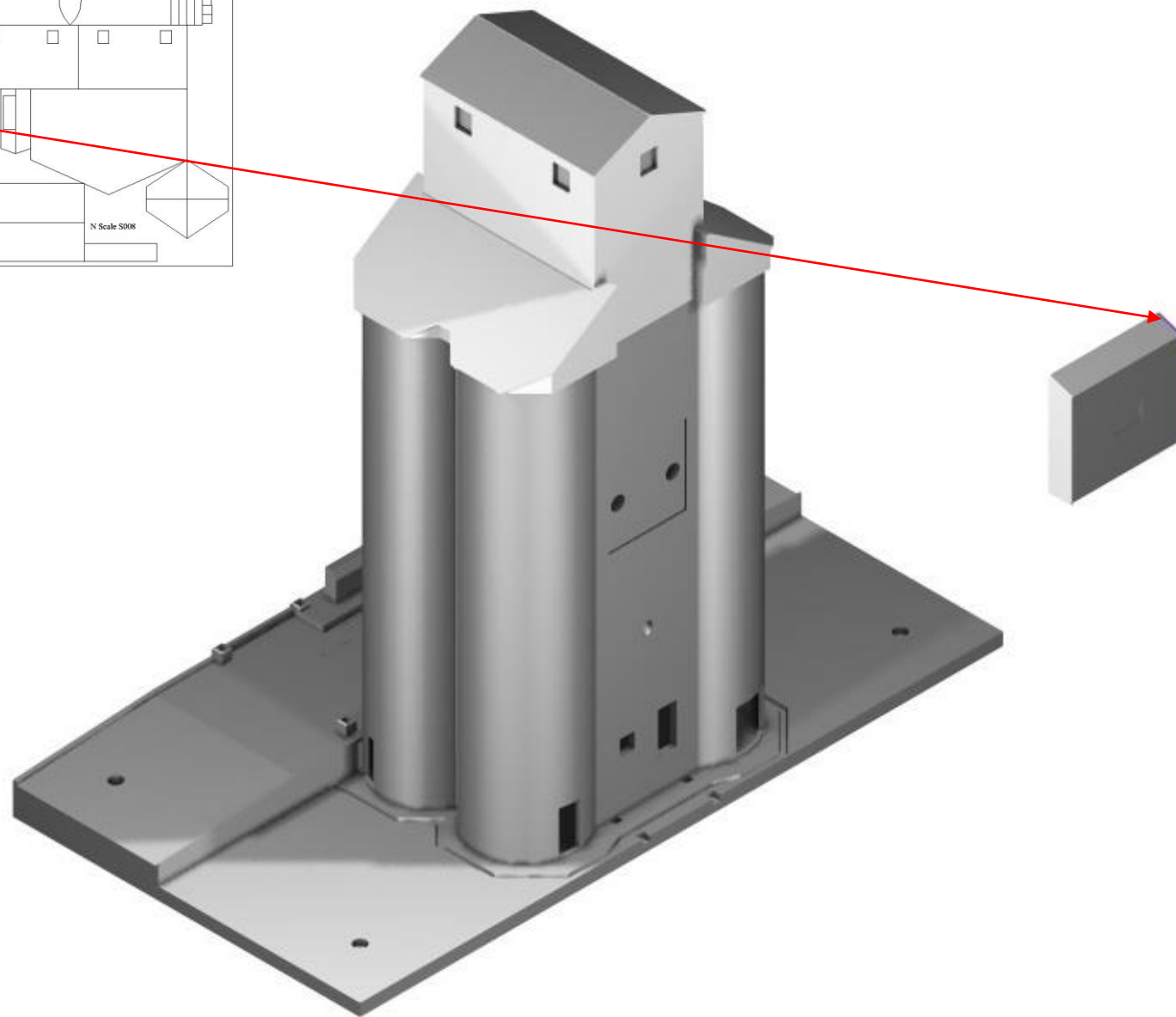
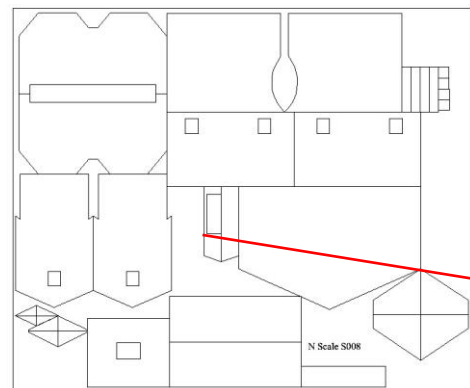

Step 22

Glue the front face of the annex in place, and lightly sand the edges to a nice smooth finish. Ensure the bottom overhang is about 0.3 mm to 0.5 mm below the main body of the annex.

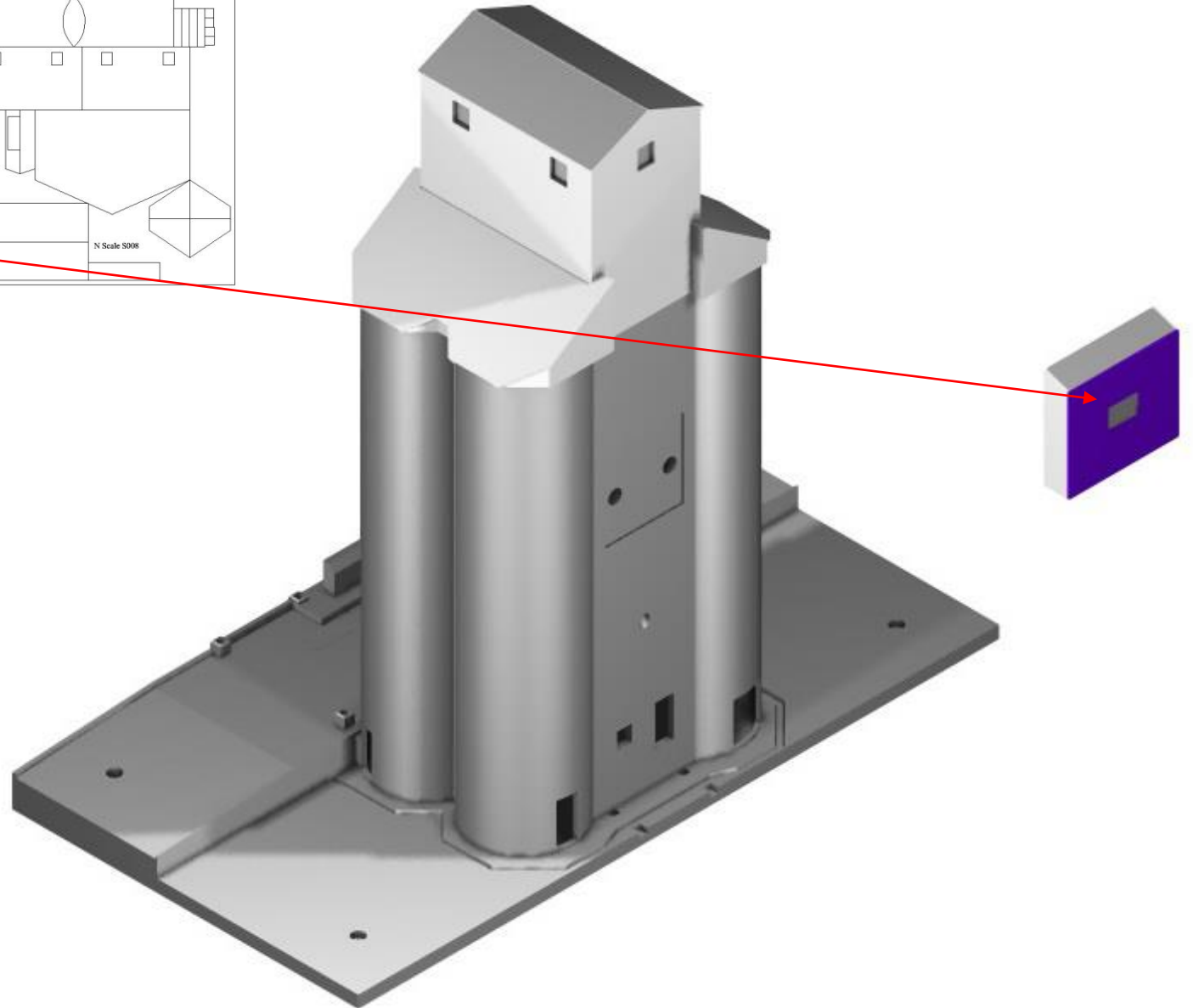
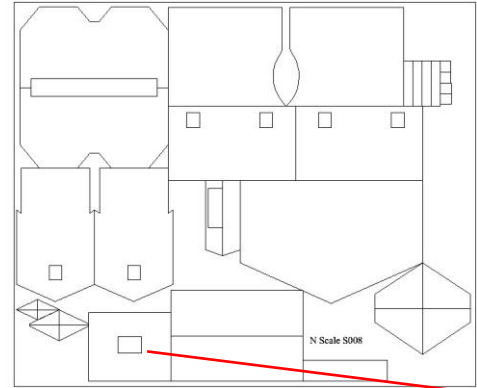

Step 23

Trim both side pieces at the rear of the annex and then glue the roof into place. The rear tips of the roof may require sanding to fit the silo wall. Once the annex has been clad, the annex can be placed aside ready for painting. A small strip of styrene can be used to simulate the gutter at the front of the roof of the annex.

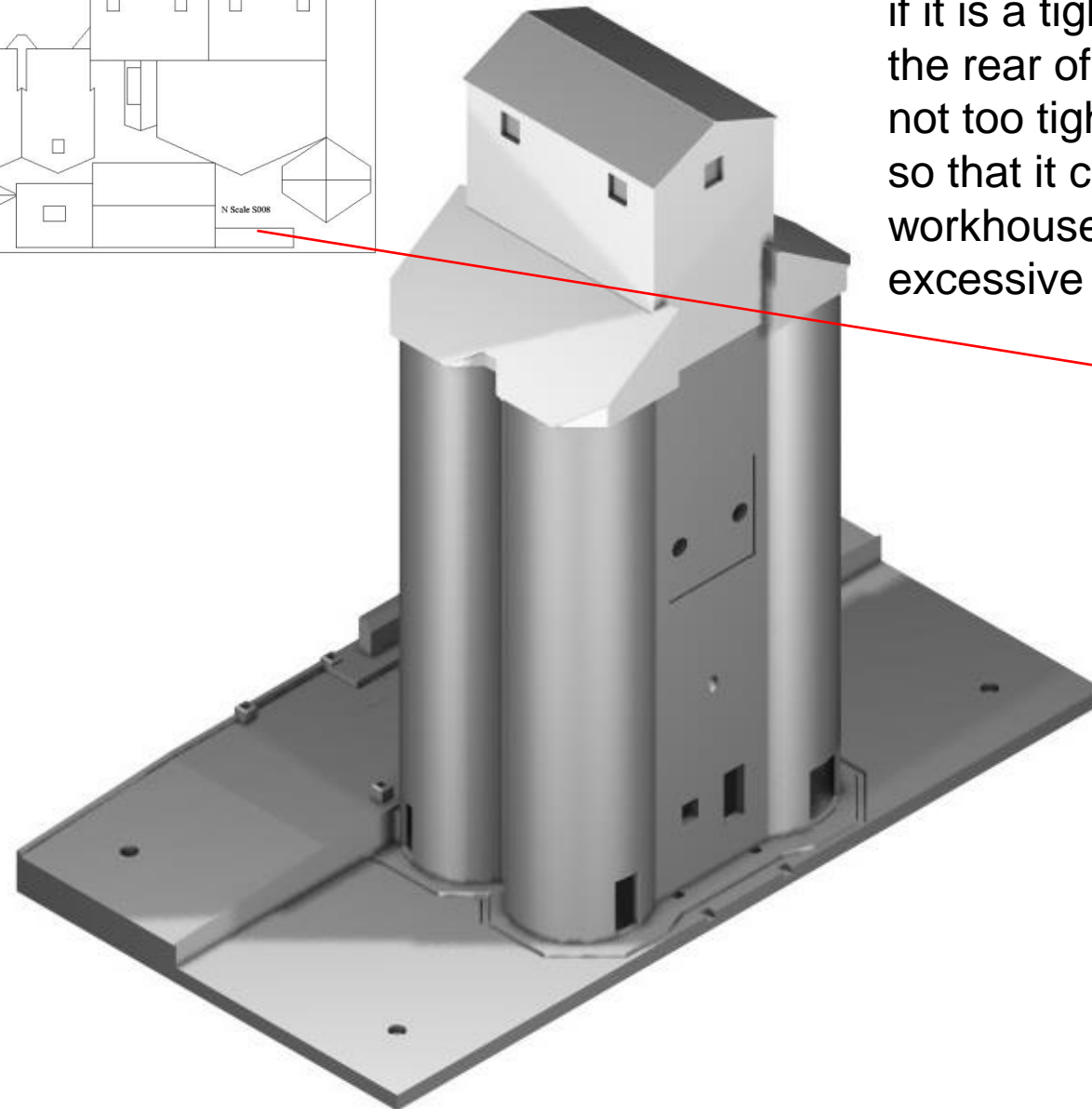
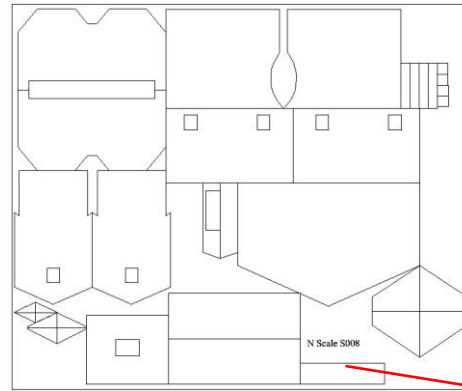

Reminder :--When working with the Annex, test fit the annex into the holes of the workhouse, and if it is a tight fit sand the pins on the rear of the annex, so that it is not too tight but just tight enough so that it comes off the workhouse with out requiring excessive pressure.

Step 24

On the base of the Annex, there is a 3D printed channel that needs to be glued under the base. This channel has 2 holes that need to be opened up using a 0.4 mm drill and a small amount of 0.3 mm brass wire, fitted forming a small hook. The hook holds the cable from the winch on the face of the silo to the out loader pivoting from the front of the silo under the annex.

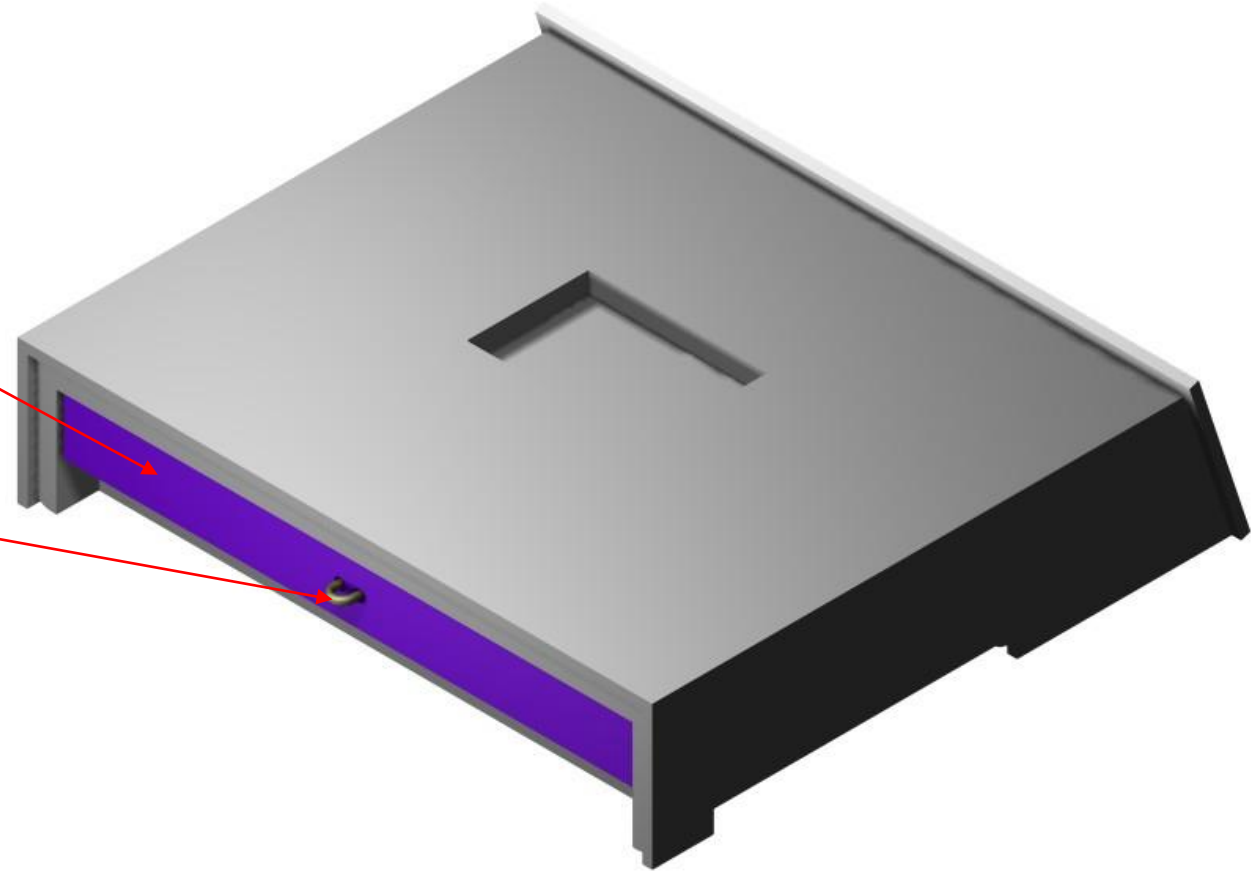

Step 25

The base of the silo has been designed to easily accept the “H” pattern columns, however there could be dags of plastic or a string of plastic inside the holes that the columns fit into. So the suggestion is, that you should test fit the columns into the footings on the base to make sure that they fit easily. Be careful when placing the columns into the footings as the footings could brake loose if excess side pressure is applied to them. Use a small square file to open up the footing holes, and sand the base of each column to assist them in fitting into the footings. They should not be tight, just a nice fit.

In the event they you do break the footing, they can be easily glued back into position by placing the column in place and holding the footing down whilst applying some liquid cement, until dry.

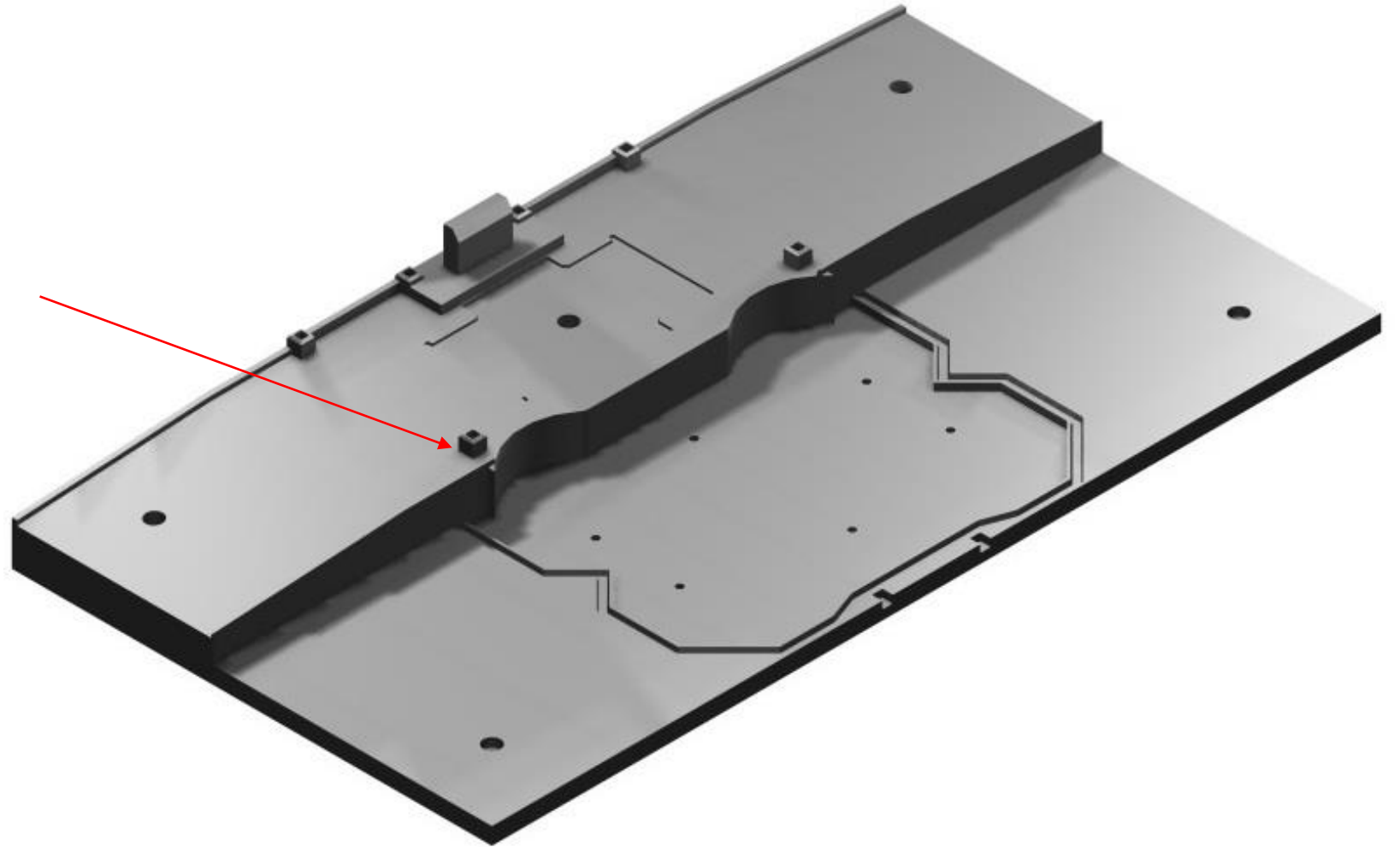

Step 26

The image opposite, is of the Wagon Frame Build Jig. It is used to make it easy for the modeller to build the wagon shed. Initially I had intended to use 0.25 mm etched Nickle Silver for the sides and roof section of the shed, unfortunately this proved to be what I would consider a more difficult task than first thought. With this in mind, I have changed the way that the wagon shed is to be built. I have still used the brass H pattern, but attached to this, are 3D printed side purlins and roof purlins. The jig is still used to secure these parts but by using 2 part epoxy such as 5 minute Araldite, or CCA Gel. This will be discussed in more detail shortly.

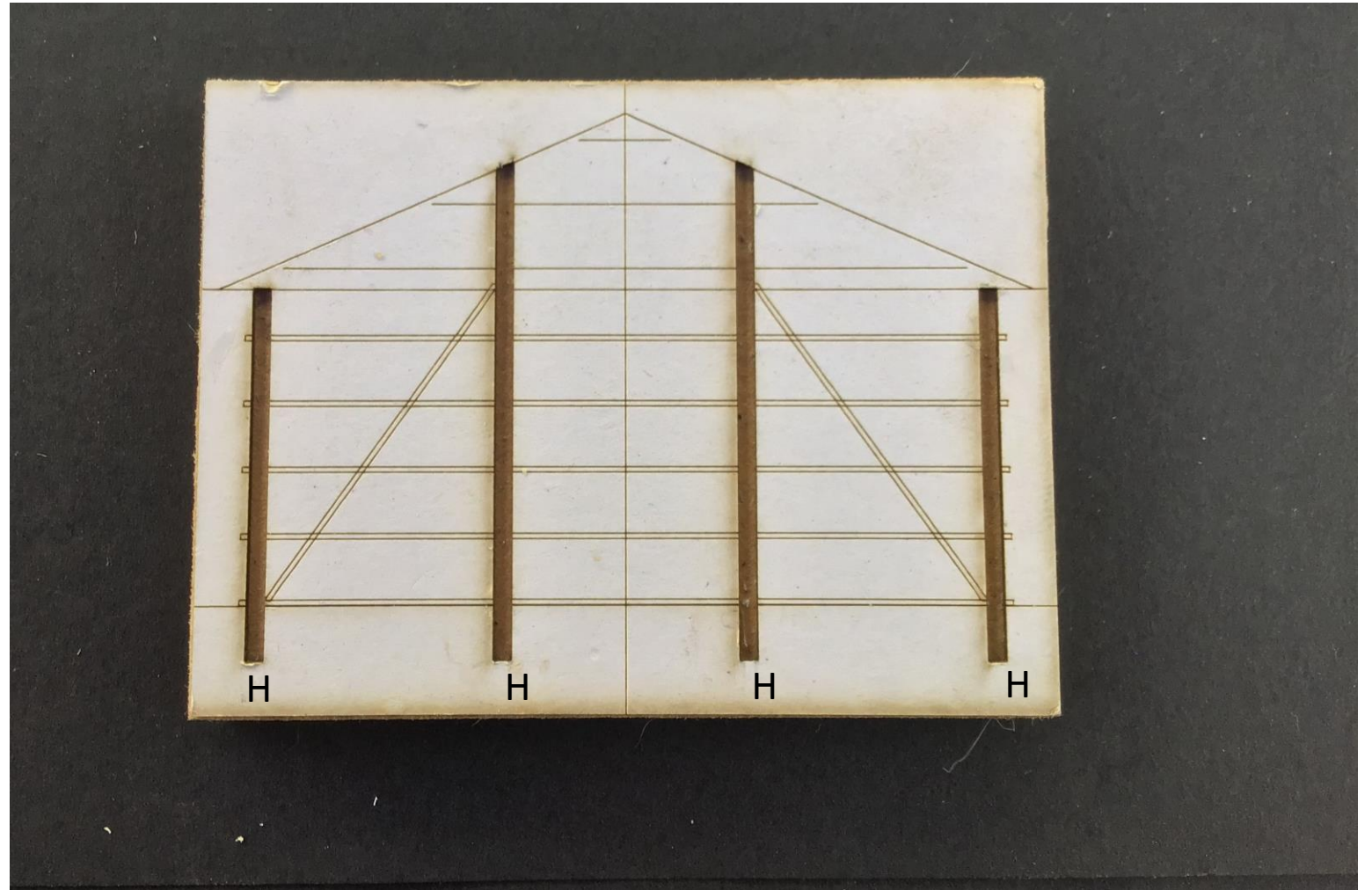

Step 27

The Wagon Shed Frame, needs to be built, using the wagon shed frame Jig. The frame is constructed from the 1/16 "H" pattern brass section. The brass needs to be cut to suit the cut outs on the jig. The image of the Jig is on the right, with the cut outs visible. The other lines are just indicators for the original etched parts. The jig is also used for the inner frame and 3D printed truss.

The columns fit neatly into the supports on the base of the silo. The orientation of the columns is shown at the base of the jig. This has been done to make the construction process easier. Normally the outer columns would be turned 90 degs.

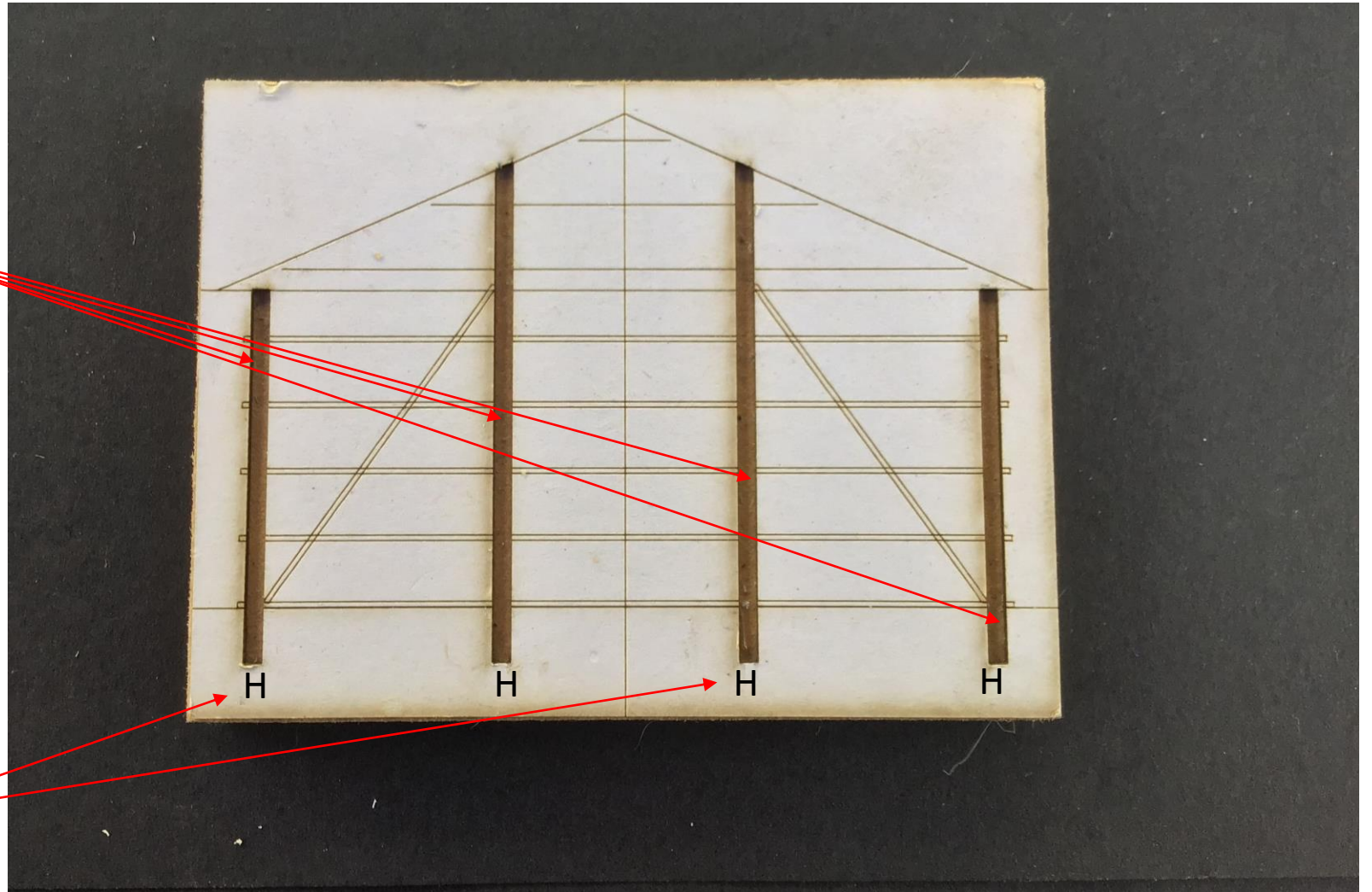

Step 28

The 3D printed outer truss and is designed so that small plastic extrusions fit neatly into the hollow of the brass beam. The printed truss with purlins, is test fitted to ensure a nice fit. Locate small dabs of CCA gel into the hollow of the brass beams, and press the truss/purlins into all 4 brass beams, and allow the CCA to dry or assist it, by using a super glue activator. Allow the piece to dry properly before removing from the jig.

Test fit the outer truss/purlins into the footings and adjust to suit.

The 3D print can be cleaned up with wet and dry and a hobby knife, to get rid of any flash or dags.

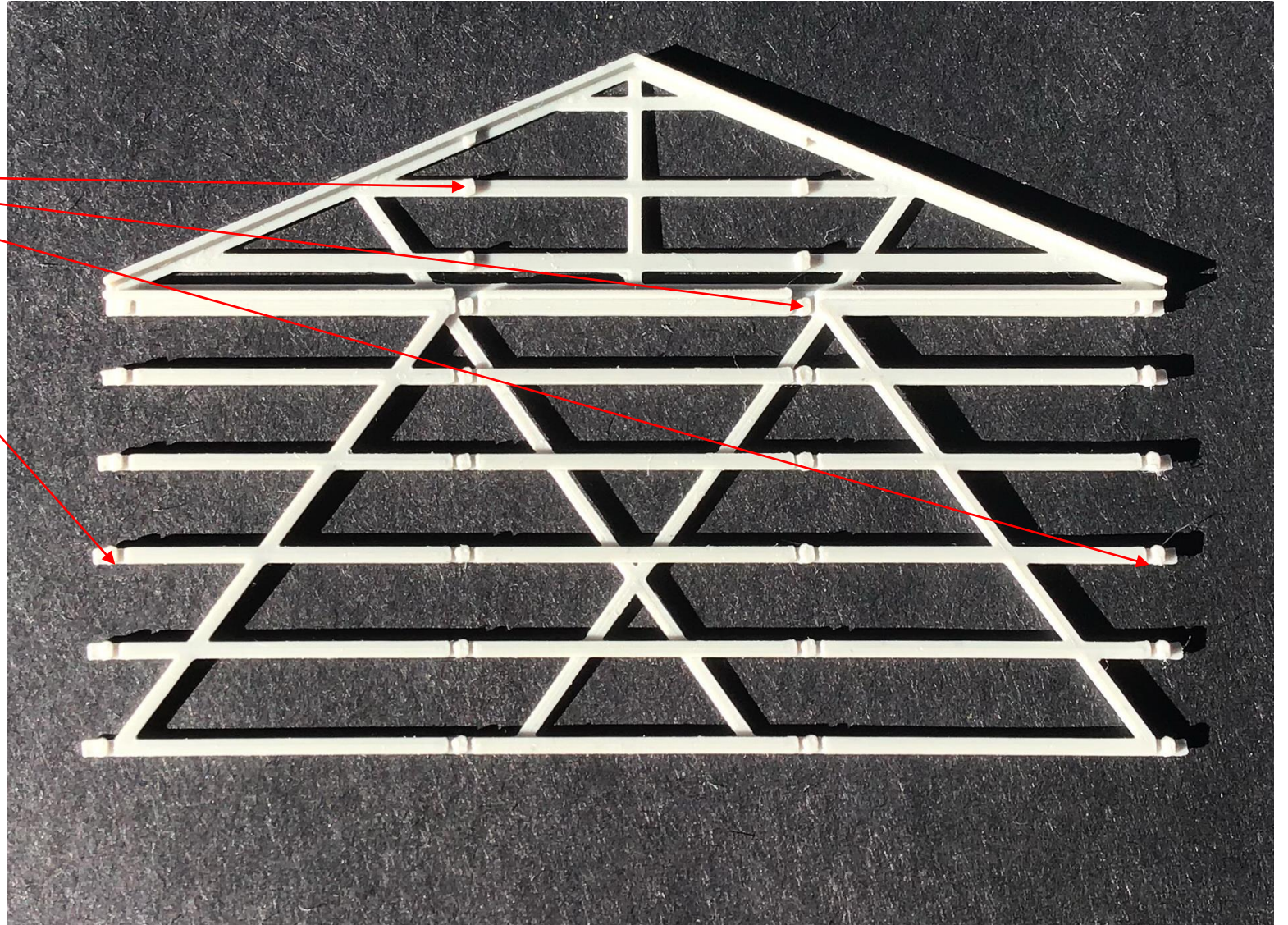

Step 29

The next step is to attach the columns to the jig in preparation for attaching the 3D outer truss and outer wall purlins. Please ensure that the columns are located as per the image to the right, and filed neatly so that they just fit into the jig.

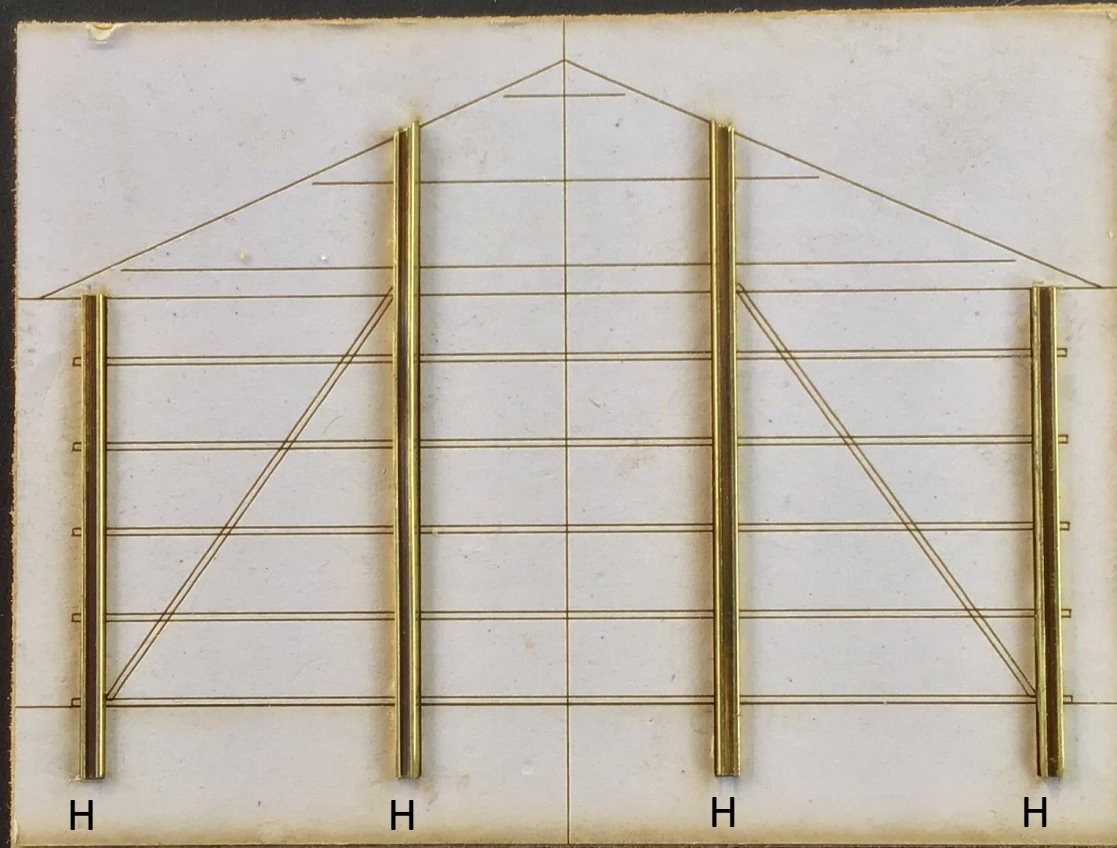

Step 30

The 3d print is located into the depressions of the columns and pressed into place, they may need some minor alterations to ensure a good fit. Once the CCA gel has dried the truss and print can be removed from the jig.

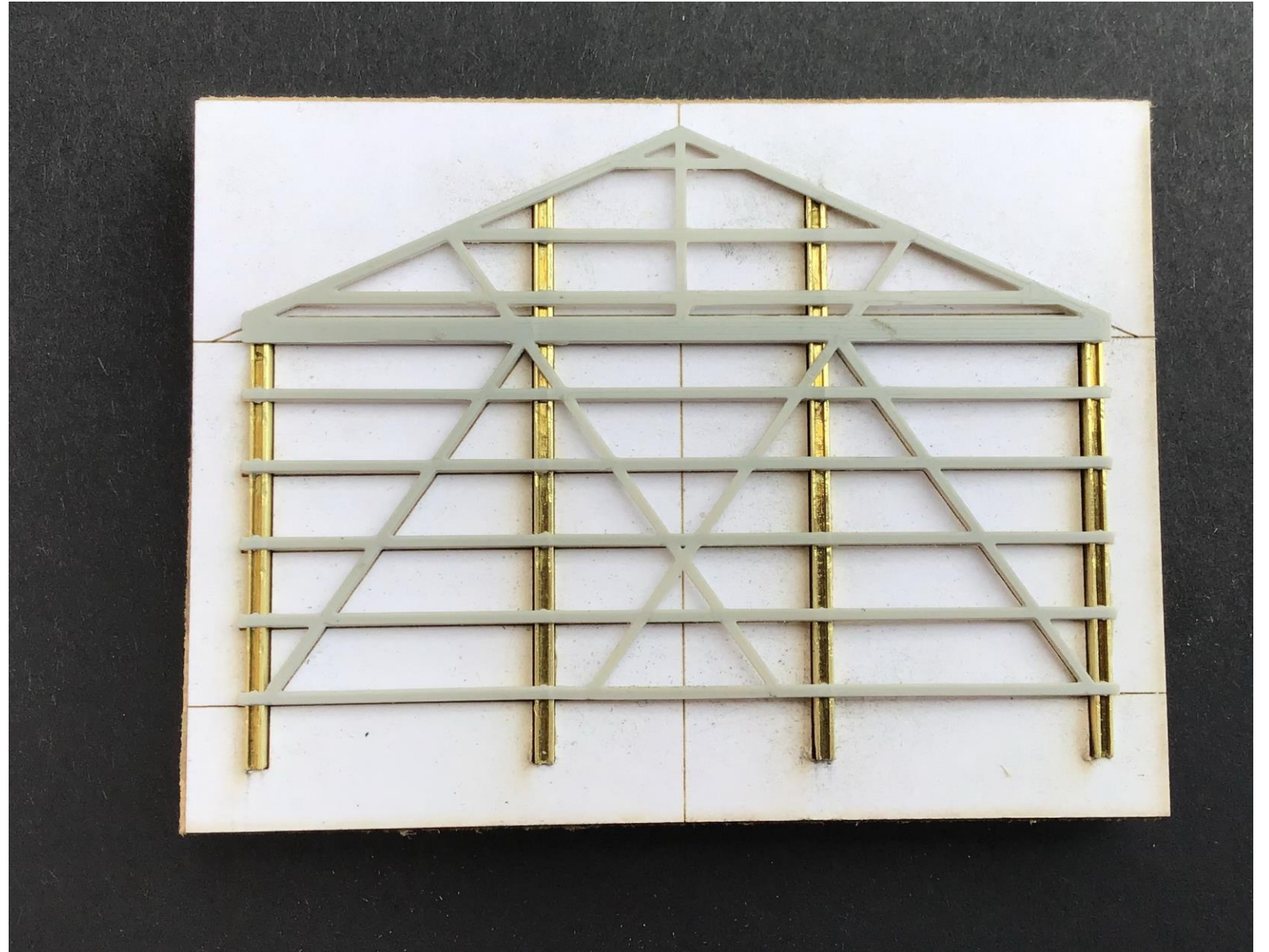

Step 31

Note that the inner columns are oriented differently to the outer columns, this is done specifically for modelling purposes. The columns are pushed into the truss, and CCA gel is placed into the joint and allowed to dry. You can accelerate the drying by use of a Zip Activator. Allow the glue to dry before removal from the jig.

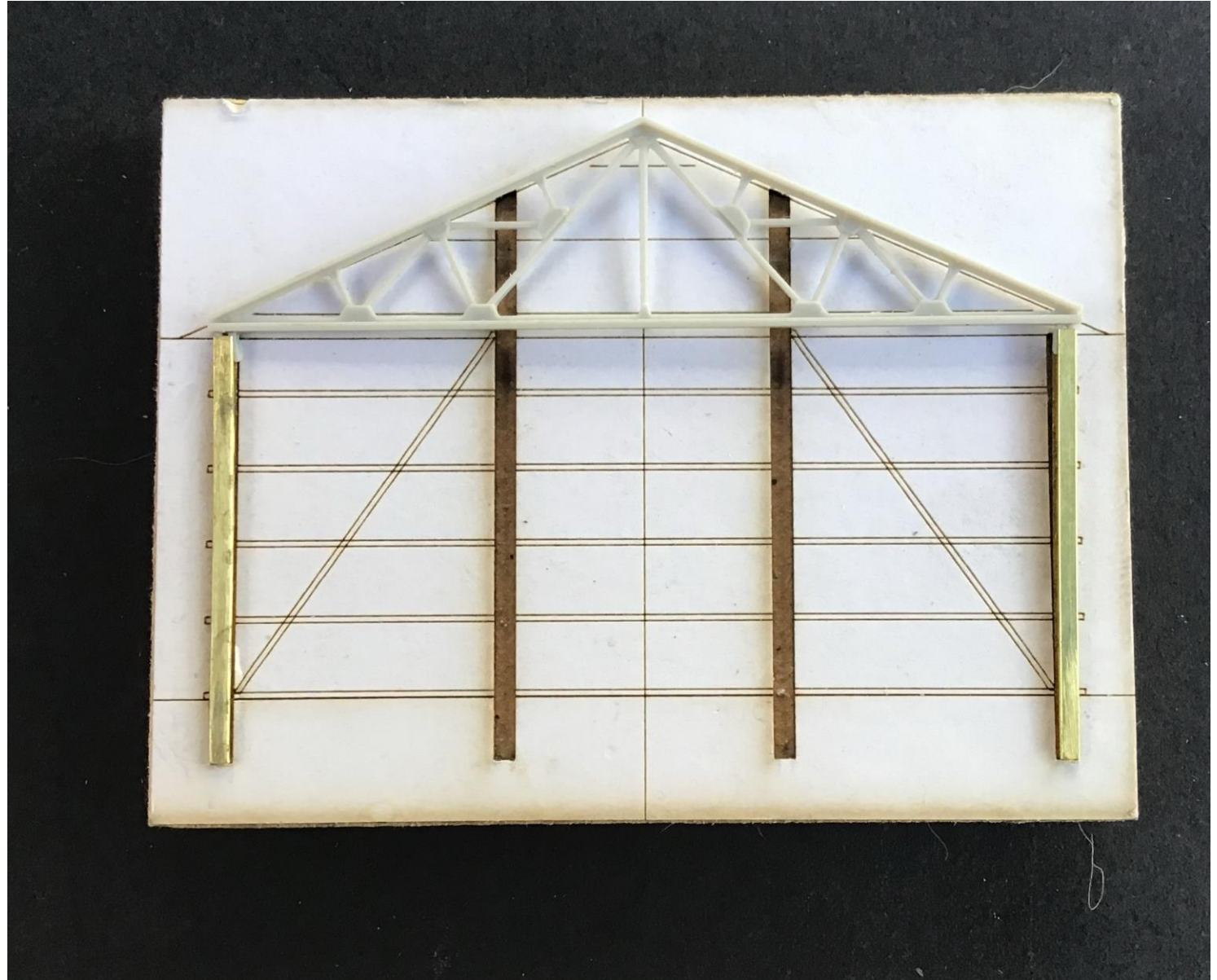

Step 32

The inner truss, can now be placed with the outer truss and secured for later fitment to the footings.

Please ensure that the columns are actually touching the bottom rail of the truss, so that there is no gap between the 2

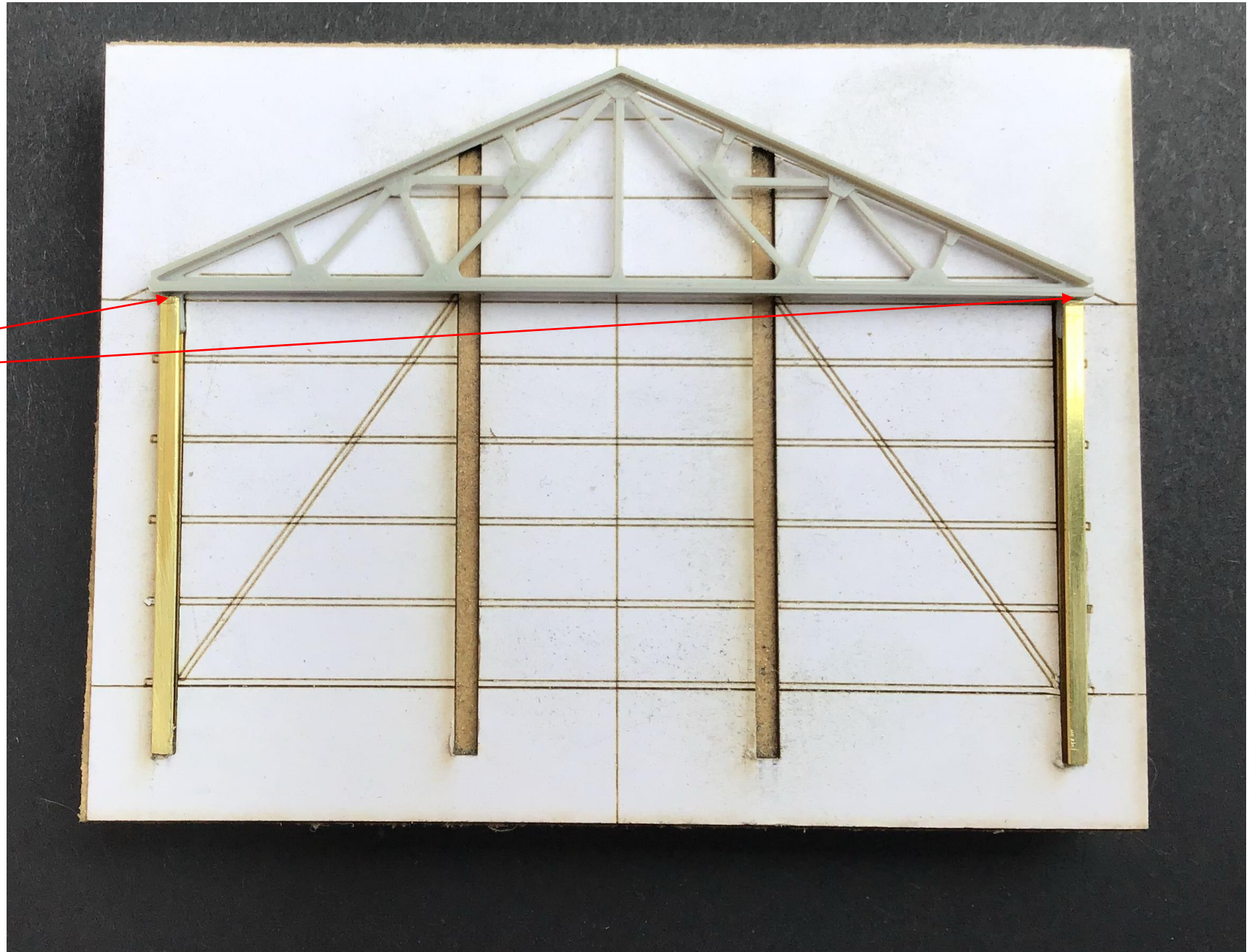

Step 33

The inner truss, can now be placed with the outer truss and placed into the footings

The roof purlins can be placed onto both trusses, and glued in place. The roof purlins are shaped specifically to the silo shapes.

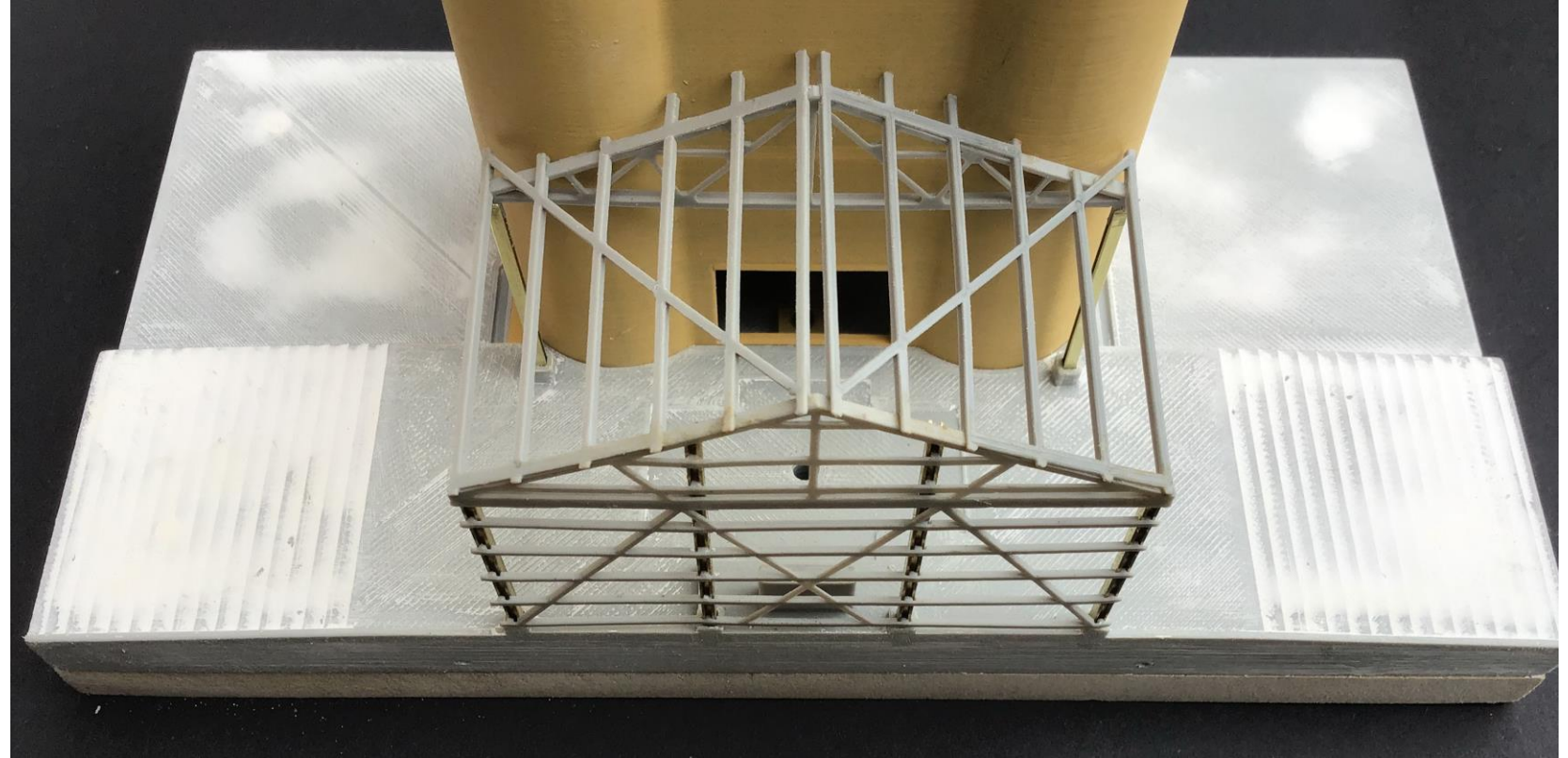

Step 34

The Corro wall and roof pieces are cut and cleaned up and glued to the outer wall and the roof purlins. Leave a very small gap between the 2 roof halves for a styrene rod to fit into. Allow the glue to dry so the wagon shed is a reasonably solid structure.

The rod and 2 pieces of thin styrene are used on this roof and the cupola roof, to form the ridge capping.

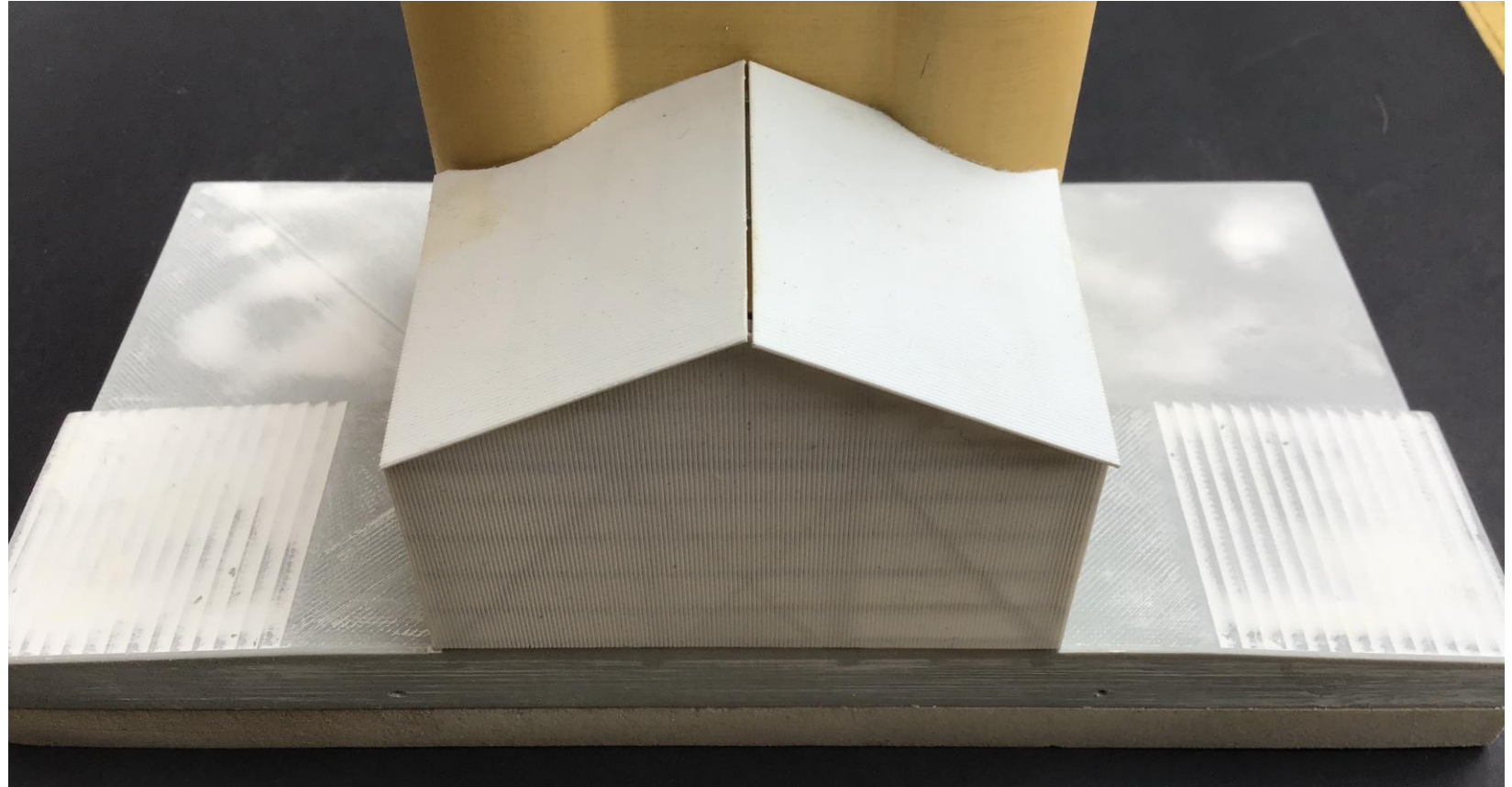

Step 35

The next parts to look at are the
Nickle Silver etches.
the parts are:

1. Rear Silo Door and Grill
2. Wagon Shed Weighbridge
3. Front Ladder
4. Front Ladder Guard

Remove the parts from the frets
only when the parts are to be
used.

The ladder guard needs to have
the holes drilled out before
removal from its fret. There are
16 holes that need a 0.3 mm
hole drilled into them. The etch
depression are in the etch.

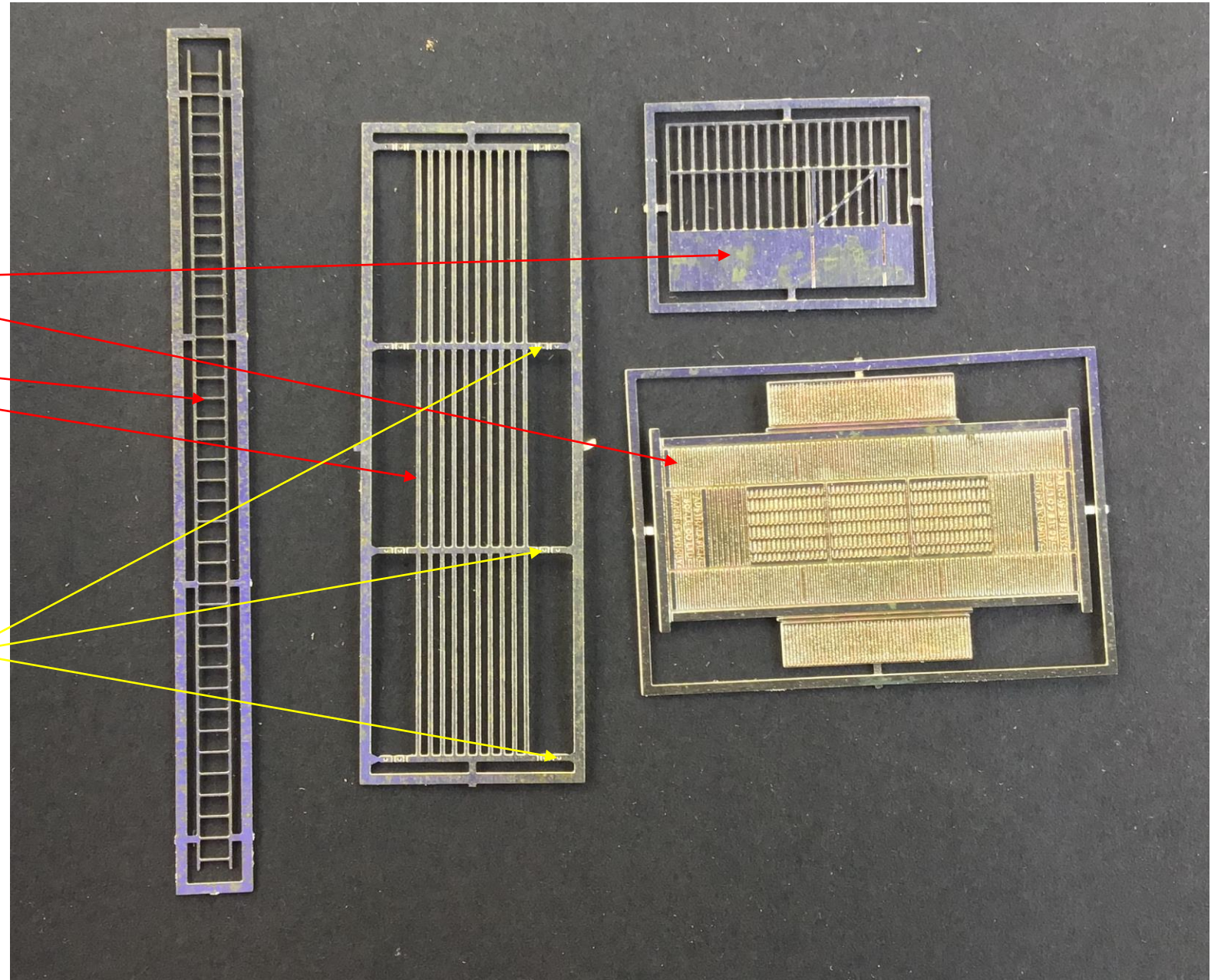

Step 36

The weighbridge fits into the void on the silo rear road, it can be glued in as one of the last jobs to do, and after painting. Remove it from the fret, and sand down the tabs so that the side of the part is clear of any excess flash.

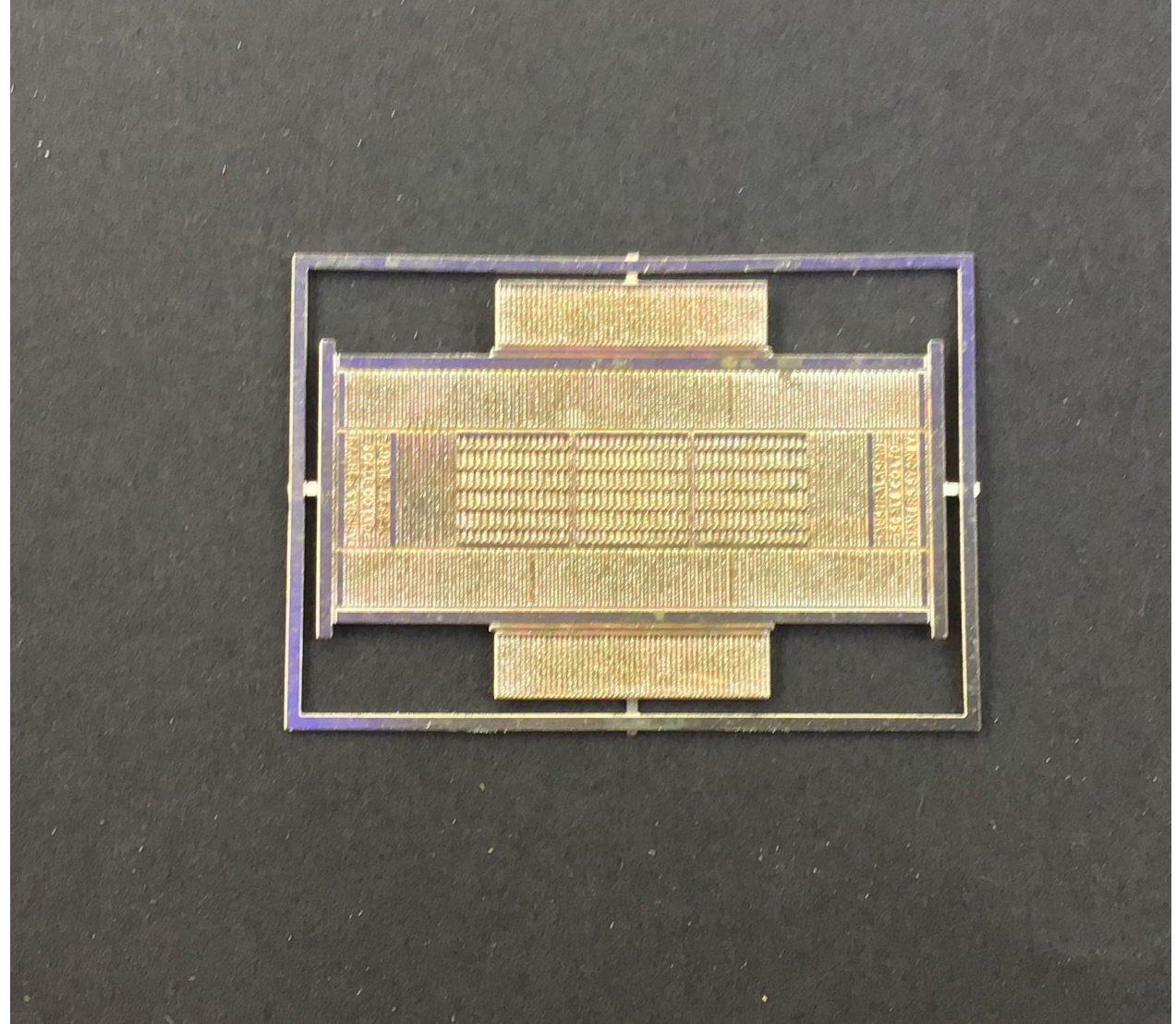

Step 37

The silo rear door is fitted into the large hole as the rear of the silo. If you find that the fit is a little sloppy, a small amount of strip styrene can be located at the base of the hole, so that the door has more contact area to attach to. The etch is required to be painted before fitting. CCA glue can be used to glue the door in place.

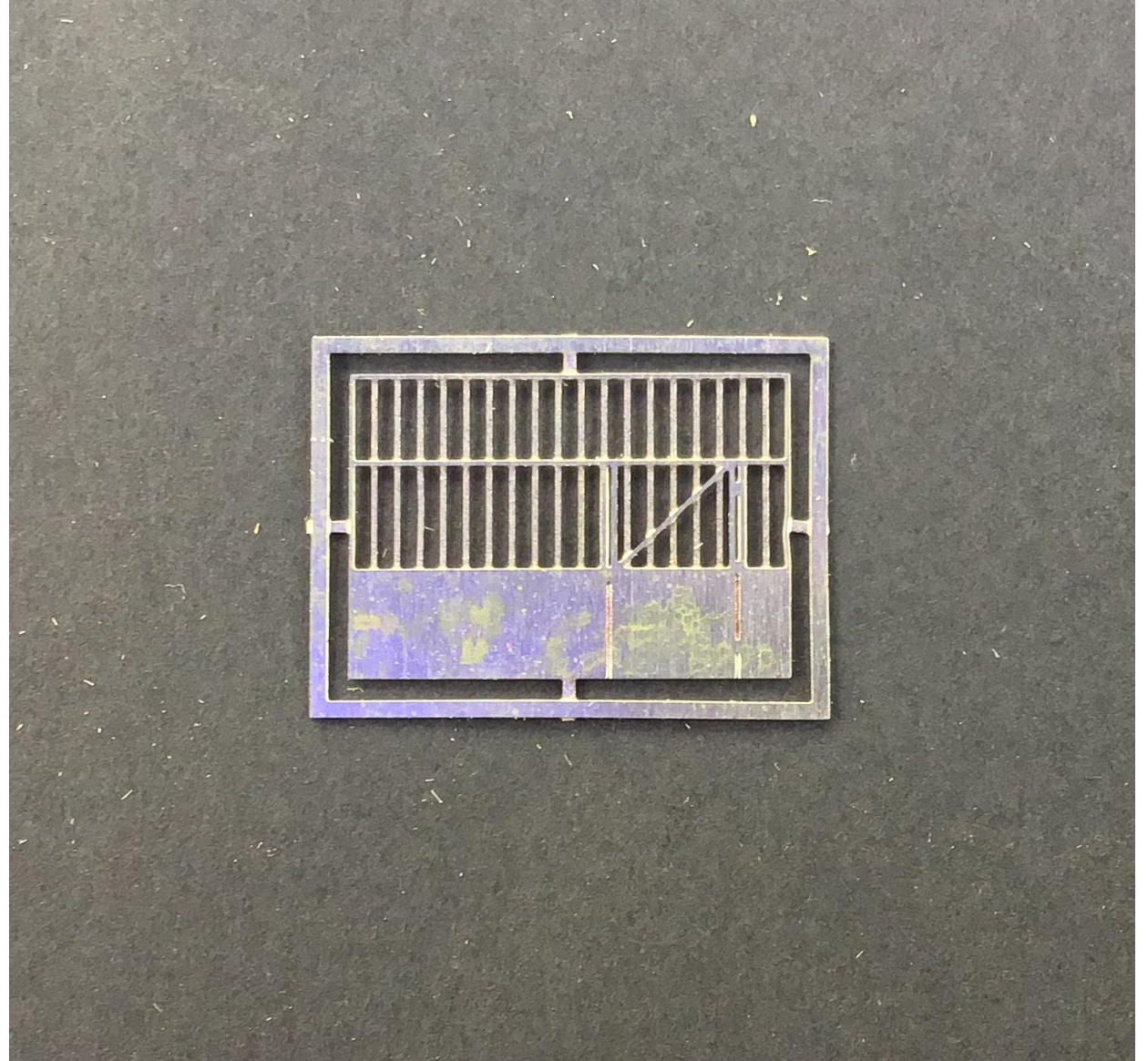

Step 38

The ladder and ladder guard go together. They are attached to the front of the silo on the curve of the right front bin to allow access from the ground to the Annex.

The dimensions for the ladder guard in the prototype are 26 inches between the sides and 33 inches from the wall to the outer curve of the guard.

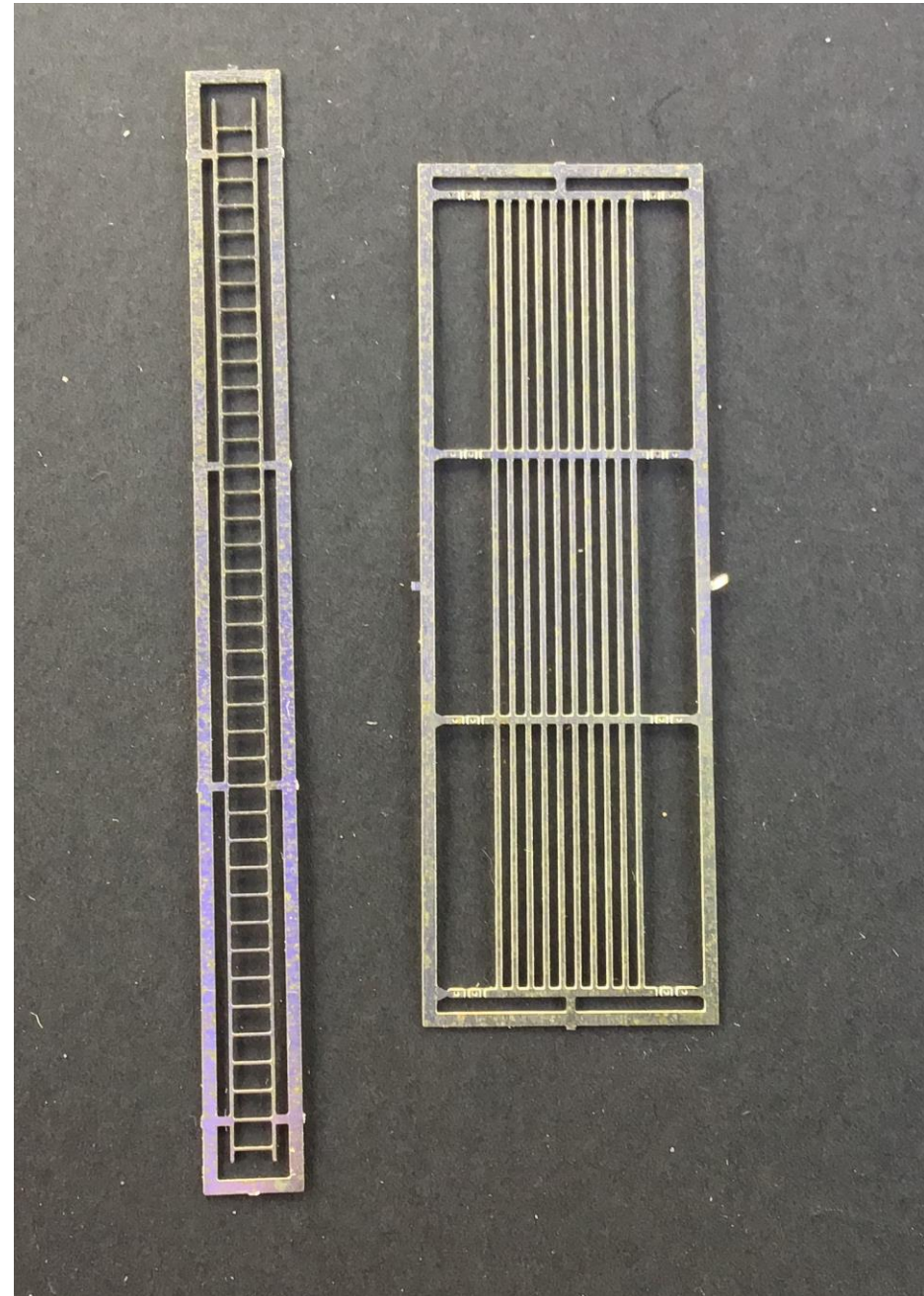

Step 39

Work needs to be done on the base of the silo. The base requires filling on both ends of the road, due to the stepping created by the printing process. this area can be sanded, filled with a good stop putty, and sanded again, this needs to be applied to both the roads and the edges of the sloped roads. The hole in the middle of the weighbridge, does not need to be filled as the etch goes over the top. The holes in the lower part of the base where the screws go through, also need to be filled and sanded. Prime the base first, before applying a coat of concrete colour.

The etched weighbridge fits here.

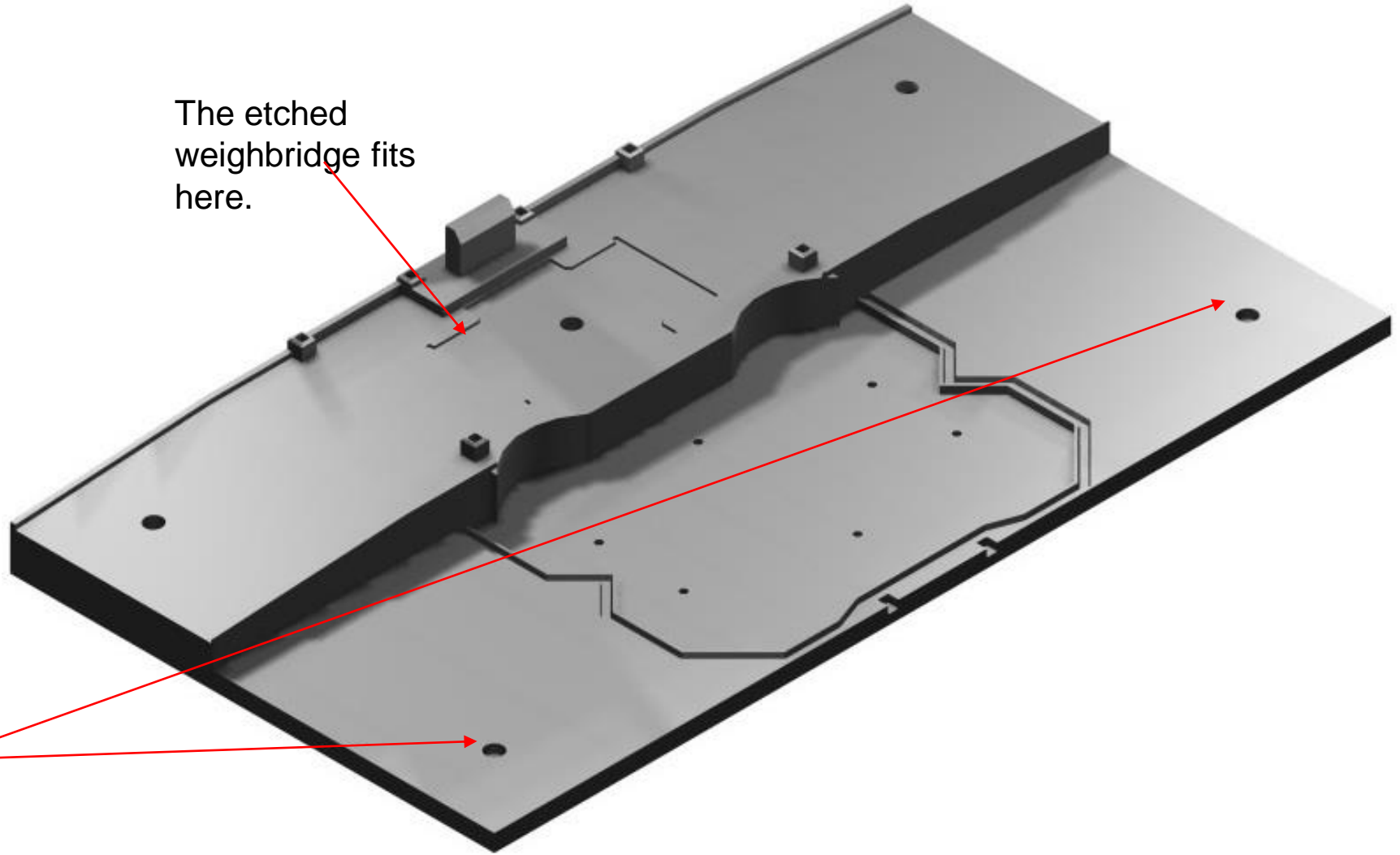

Step 40

The out loading chute:

Included in this kit there is:

A length of 3 mm brass tube X 19 mm

A length of 3 mm brass tube x 10 mm

A length of 0.8 mm brass tube x 5 mm

A length of 0.5 mm brass wire x 6 mm

A length of 0.3 mm brass wire x 10 mm

A length of 3 mm x .25 mm flat brass strip x 15 mm

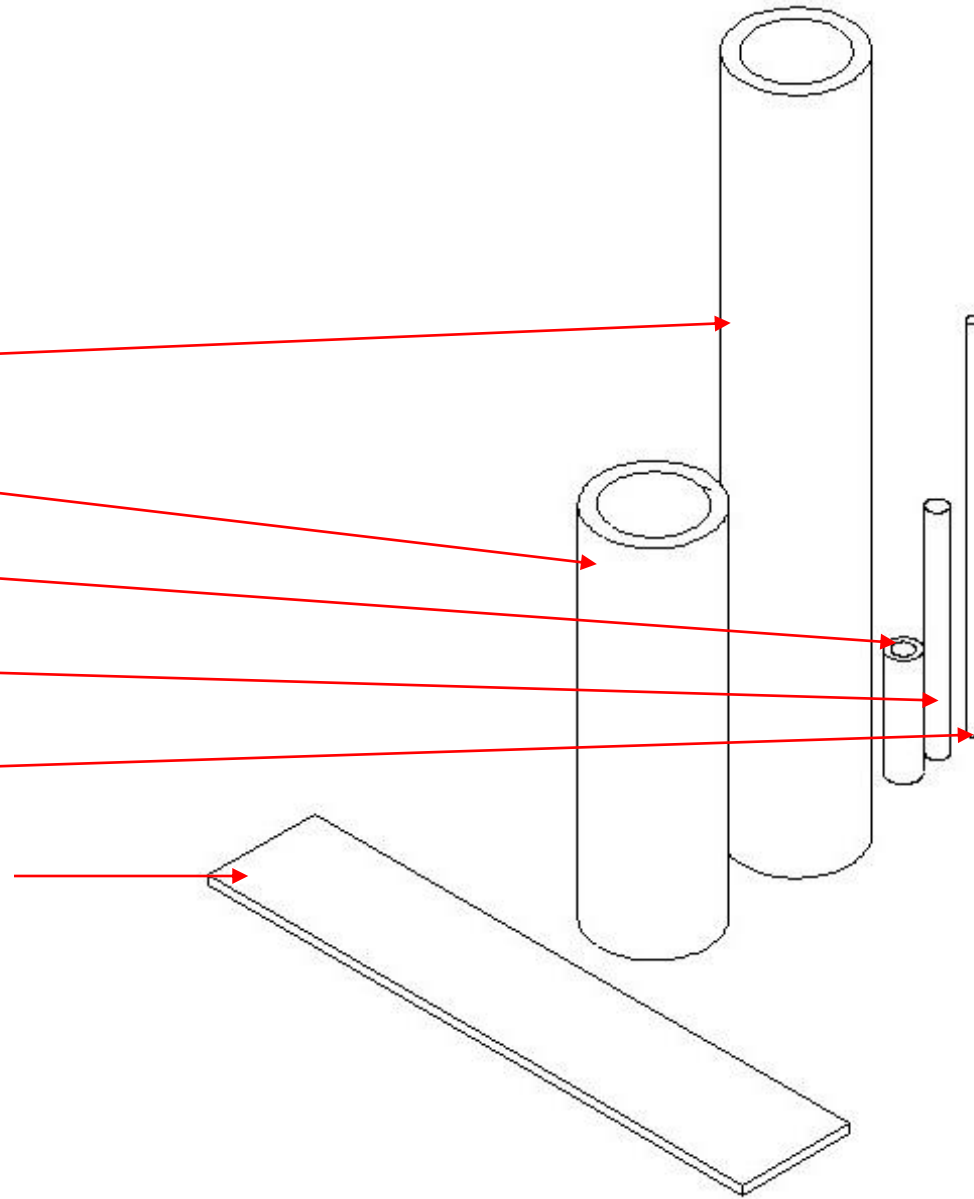

Step 41

The out loading chute:

Trim the 3 mm strip down to 2 mm

Solder the 0.8 mm tube square to the long 3 mm tube
And file the small tube so that it is flush with the 3 mm tube sides

Locate the short tube 0.9 mm from the edge of the brass strip

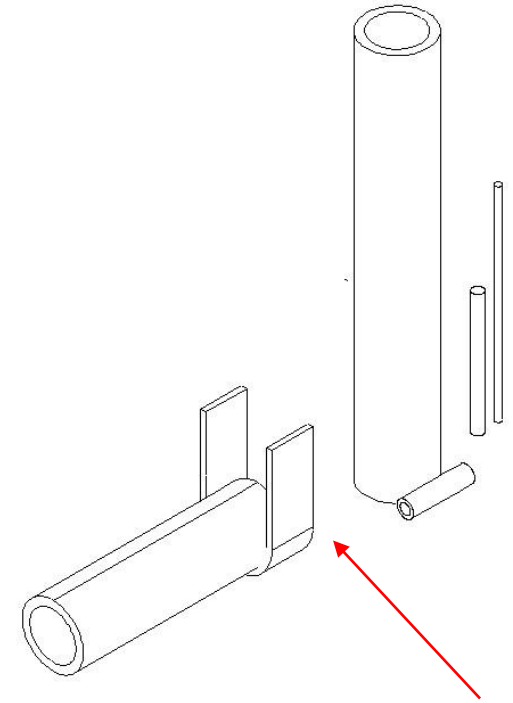
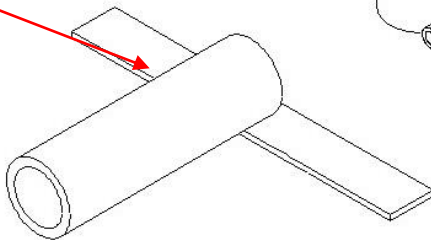
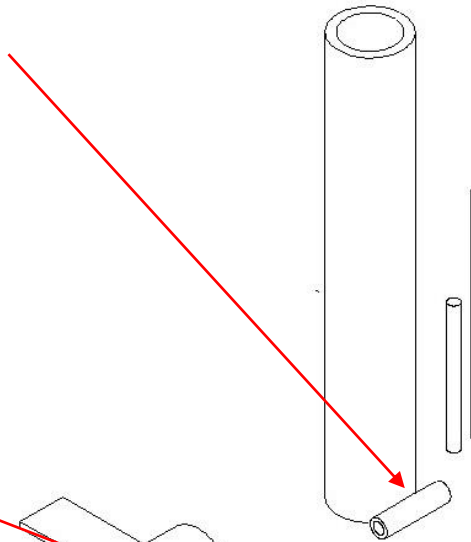
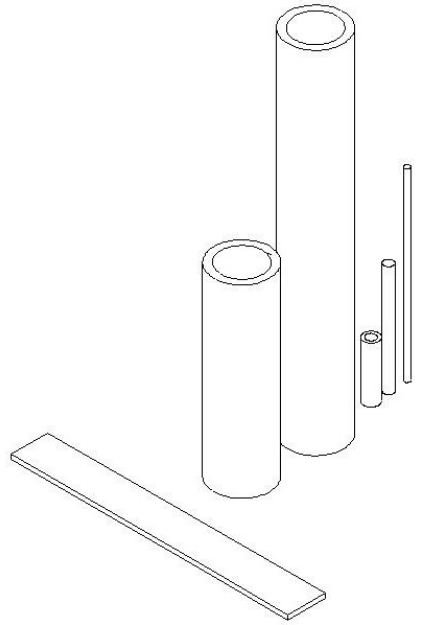

Fold the strip around the short Tube so that it is square and horizontal, and solder the tube to the brass strip.

Step 42

The out loading chute:

Locate the long 3 mm tube so that the small tube is 0.6 mm from the front edge of the brass strip

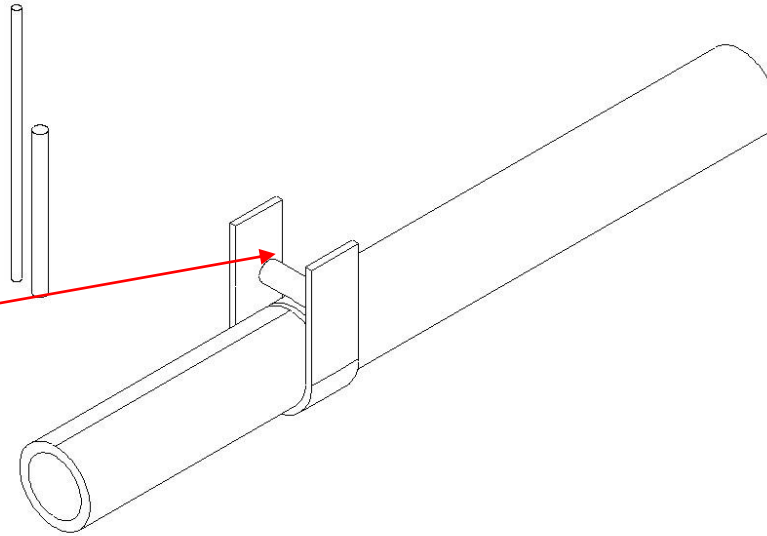

Make a mark on the side of the strip that lines up with the centre of the 0.8 mm tube. Drill a 0.5 mm hole through the strip and through the tube to the other side of the strip. This will form the pivot of the out loader chute.

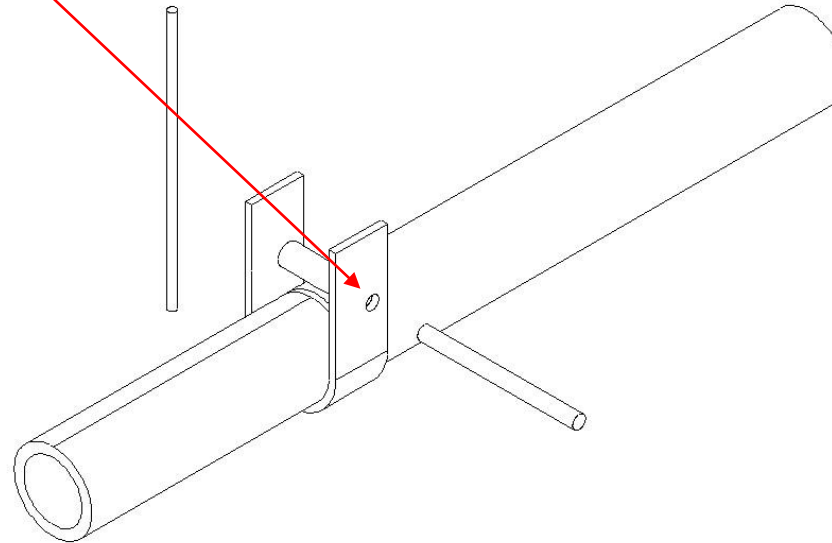

Step 43

The out loading chute:

Locate the 0.5 mm wire into the hole and solder the wire to the brass strip only. Avoid soldering the wire to the tube, as it will stop any chance of pivoting.

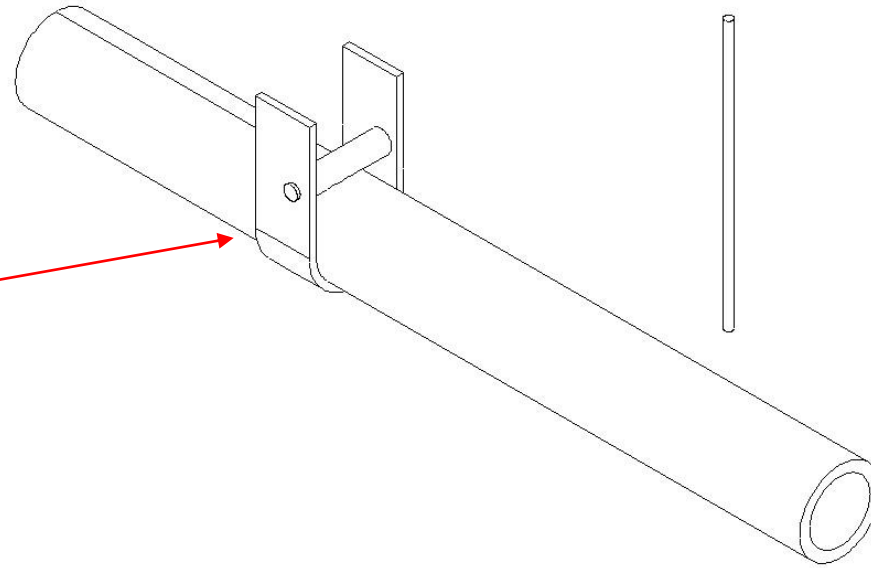

Cut the brass strip to a shape similar to the image to the right.

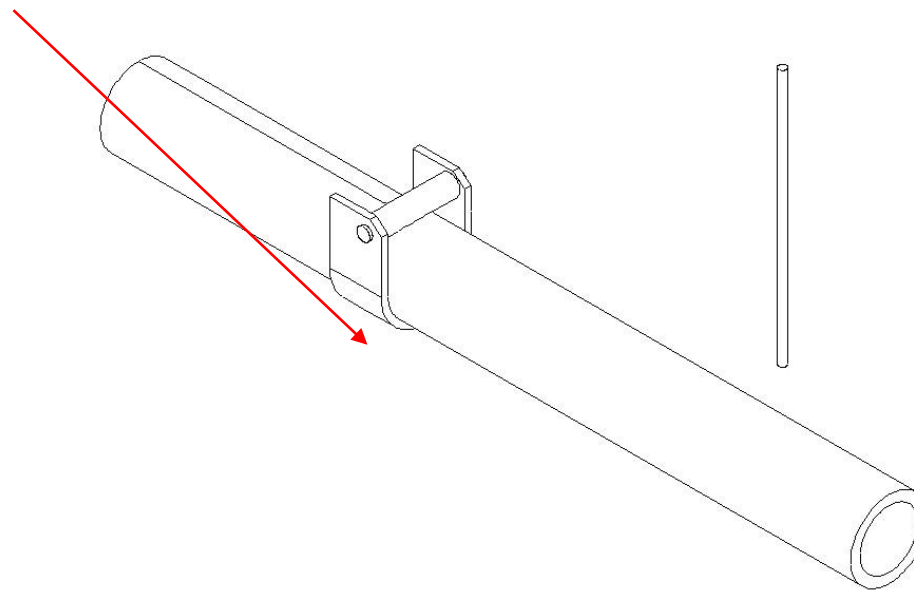

Step 44

The out loading chute:

Drill a 0.3 mm holes 1 mm in from the end of the long tube, then another 1 mm hole 1 mm in again. Bend a piece of 0.3 mm wire to form a loop.

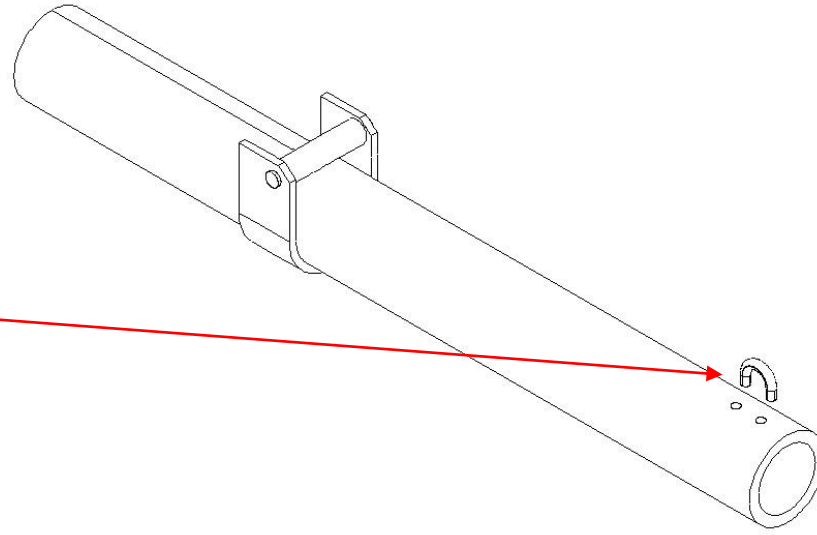

Fit and solder the bent wire into the holes, this is where the cable runs from the winch through the hook under the Annex.

The out loader is located into the angled hole under the annex, with the short end located up to the brass strip section

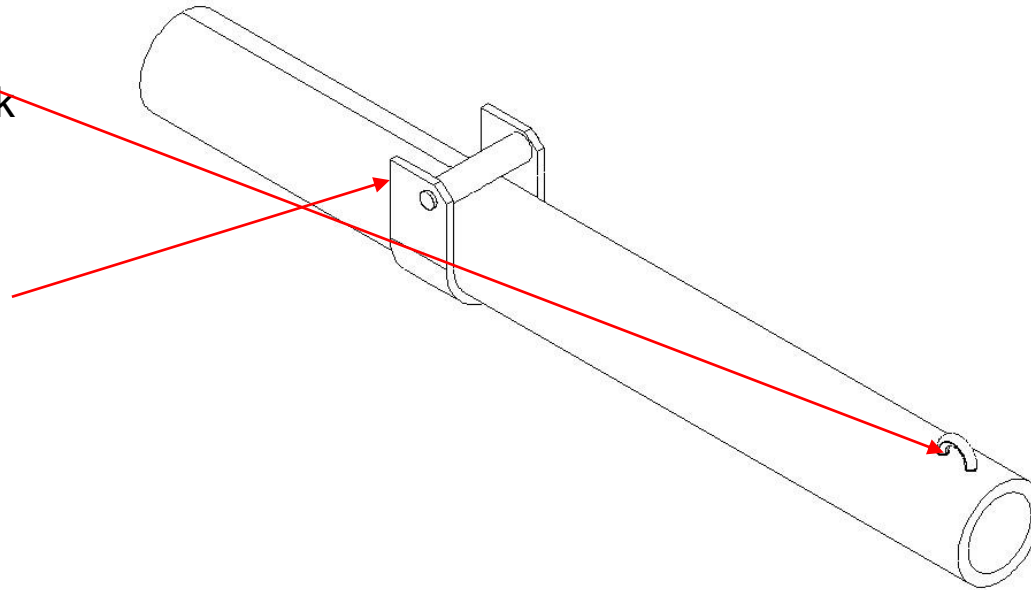

Step 45

Ladder and ladder guard

The ladder and ladder guard are next. Some work will need to be done with the ladder guard before it can be located into its correct position. The 16 holes will need to be drilled using a 0.3 mm drill. Please do this before removing the ladder guard from the fret, the guard also needs to be folded around a 5 mm drill and the ends with the holes folded and soldered to locate the ladder and to also locate the ladder guard against the front of the silo. The ladder guard needs to be folded so that the **folding tabs** are on the **inside** of the ladder guard. It will also need to be located so that it is square to the silo.

This etch is very fragile, and needs to be handled very carefully. You have an option as to how it is secured to the silo wall, you locate small sections of 3 mm wire through the holes and drill holes into the silo wall, or you can glue the ladder guard onto the silo wall. This is all dependant on your skill levels with soldering, and handling fine etches.

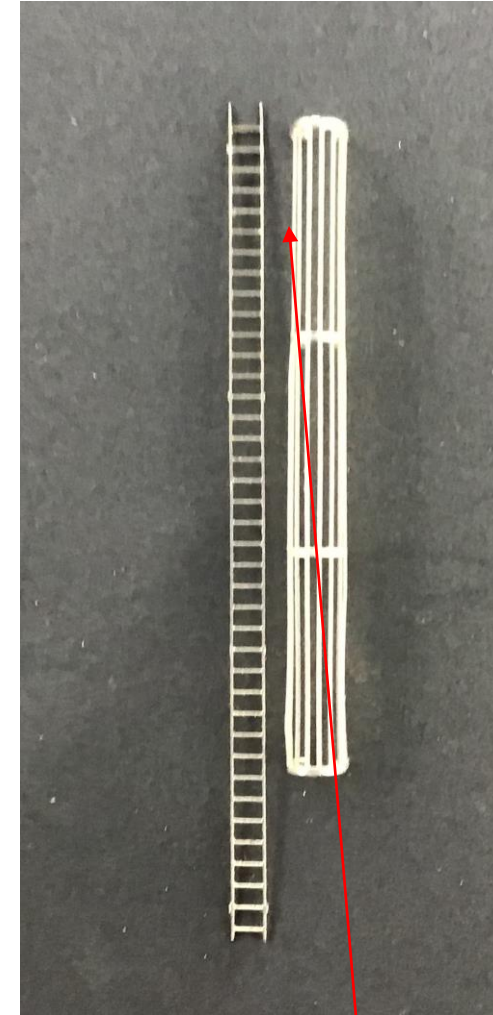
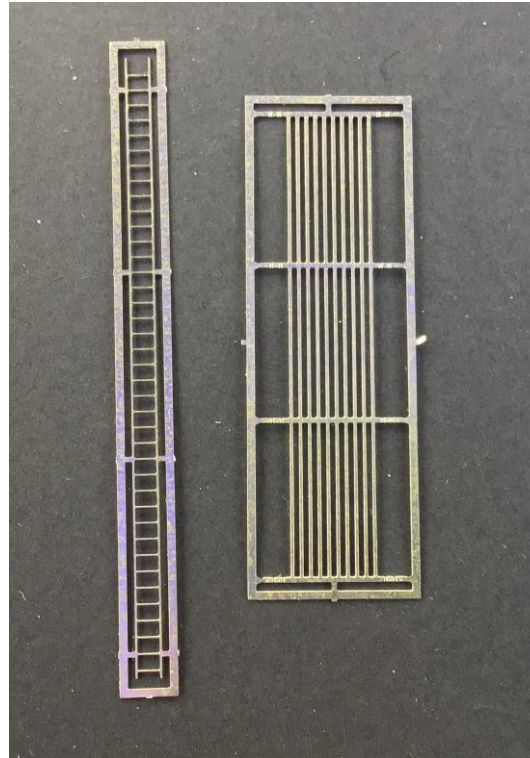

This image shows the position of the ladder in relation to the ladder guard. The top rung of the ladder is level with the top of the ladder guard. The 2 vertical pieces in the top section (only) of the ladder guard need to be removed to gain access to the annex.

Step 46

Ladder and ladder guard

The ladder and ladder guard are located with the 2nd top horizontal bar just under the annex. When locating the annex to the silo wall, please ensure that the ladder and guard are square to the silo.

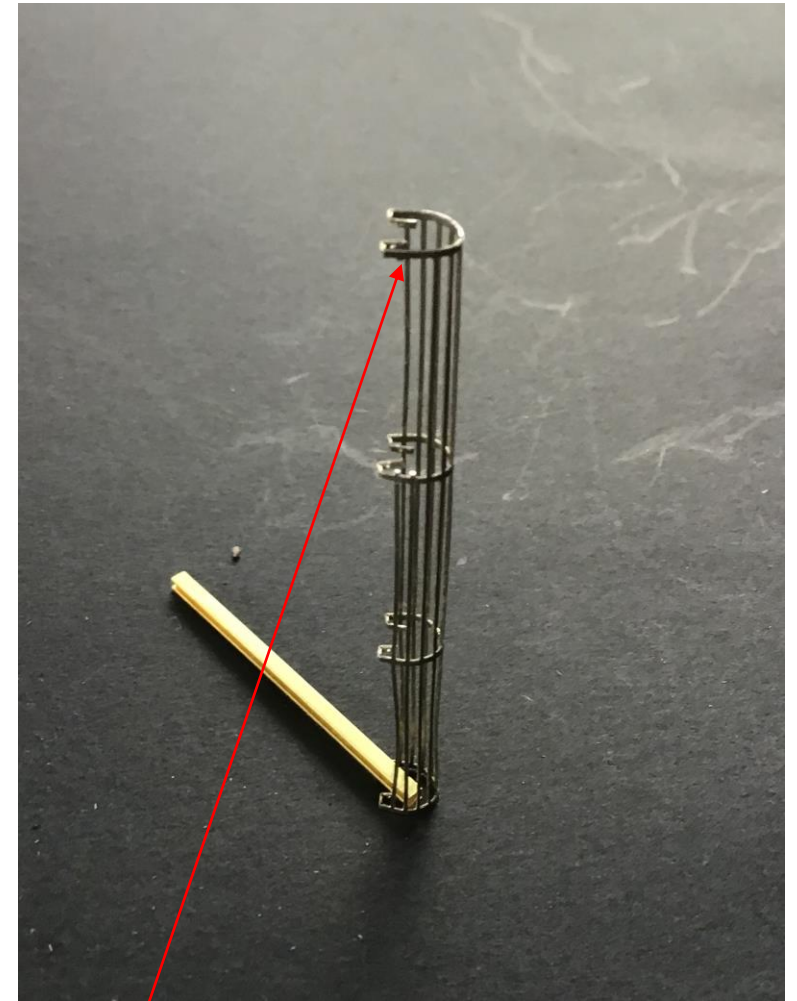
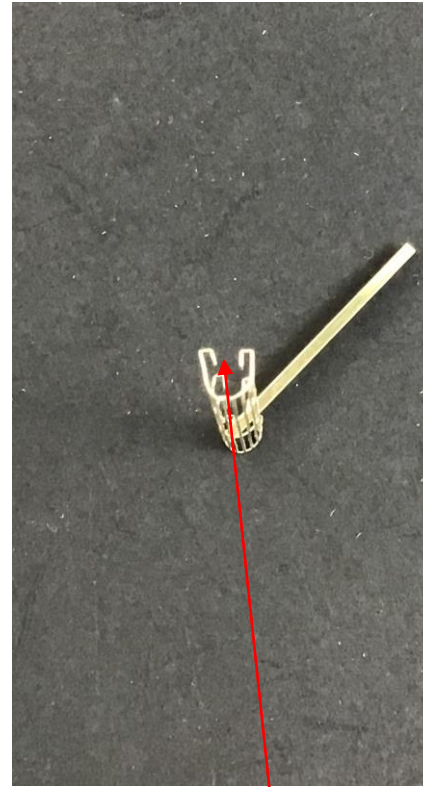

The image to the left, shows how the etch is folded to allow the ladder guard to attach to the silo wall.

The 2 vertical pieces in the top section (only) of the ladder guard need to be removed to gain access to the annex.

Step 47

The very small winch:

The winch kit includes:

0.3 mm Wire x 10 mm long

0.6 mm Tube x 2 mm long

0.3 mm Nickle Silver plate x 2

Place the 0.6 mm tube onto the 0.3 mm wire. Slowly file the tube down to 1 mm long. Locate the tube 2 mm from the end of the wire

Square up the 2 Nickle Silver plates and attach them on both sides of the tube.

Bend the wire at the long end of the plate, 90 degs.

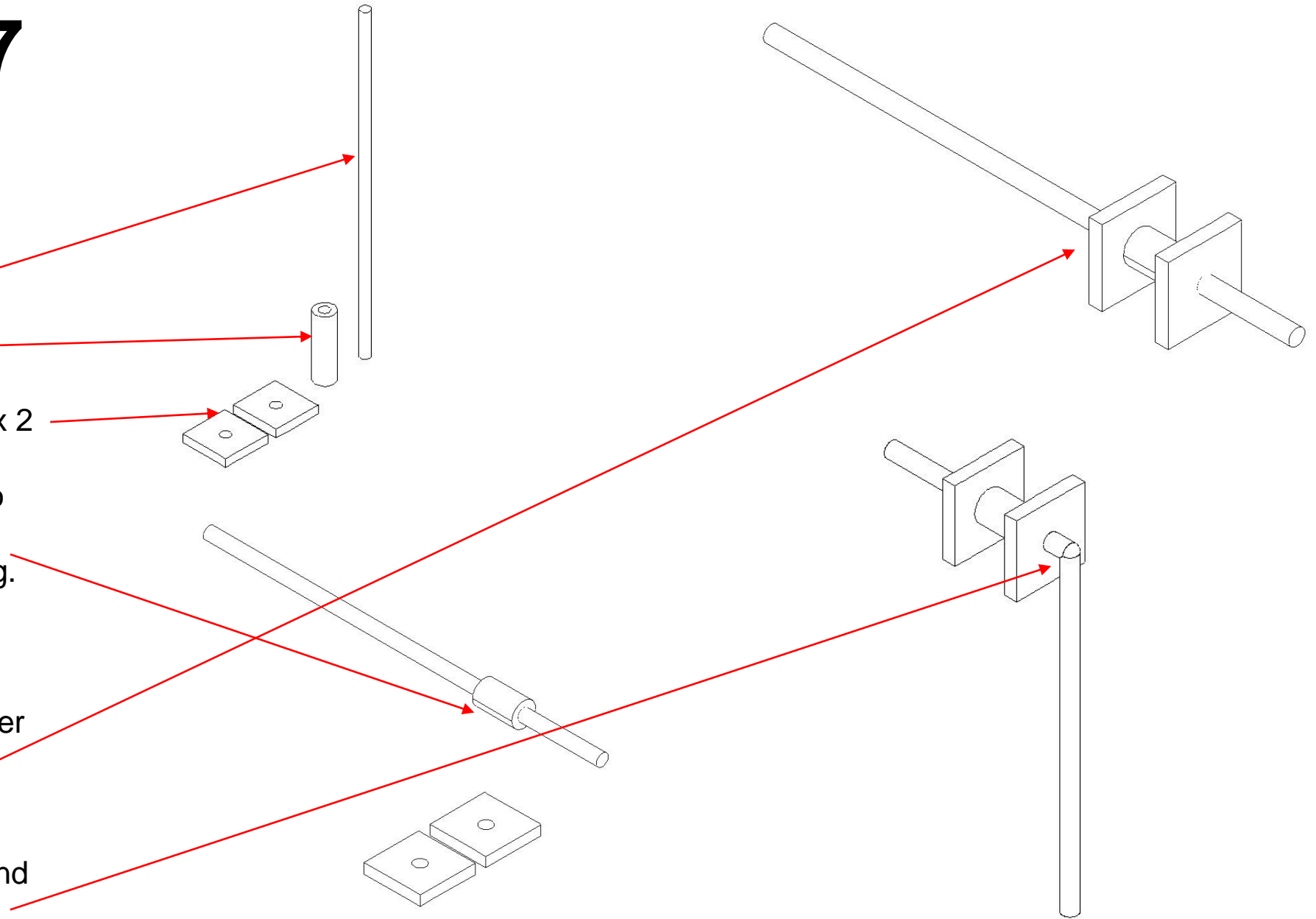

Step 48

The very small winch:

Bend the wire again at 90 deg, leaving you with a winch that looks similar to the image on the right.

Drill a 0.3 mm hole in the front wall of the silo just under the louvered vent opposite the silo front door.

The straight 0.3 mm wire end of the winch is placed and glued into this hole.

You can clean up the nickel silver plates so that they end up round if you want, but it is not fully necessary.

There is a length of cable that is in the bag with the Annex, this cable goes from the winch up to the base of the annex and attaches to the out loading chute.

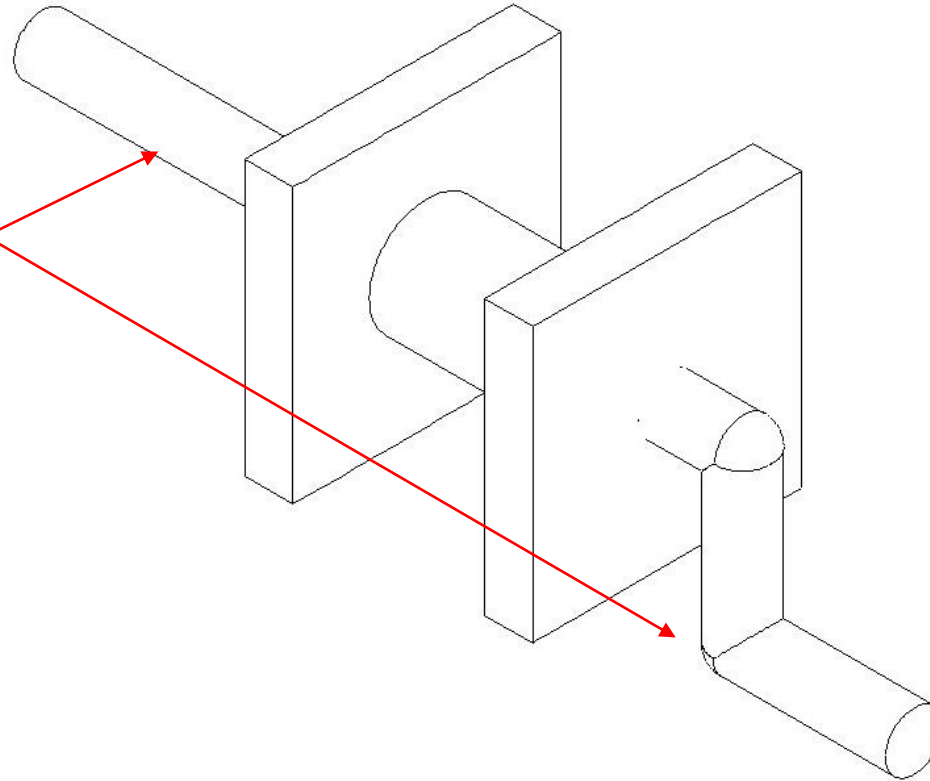

Step 49

The winch is located at the front of the silo under the louvered vent window.

The out loader is also located here

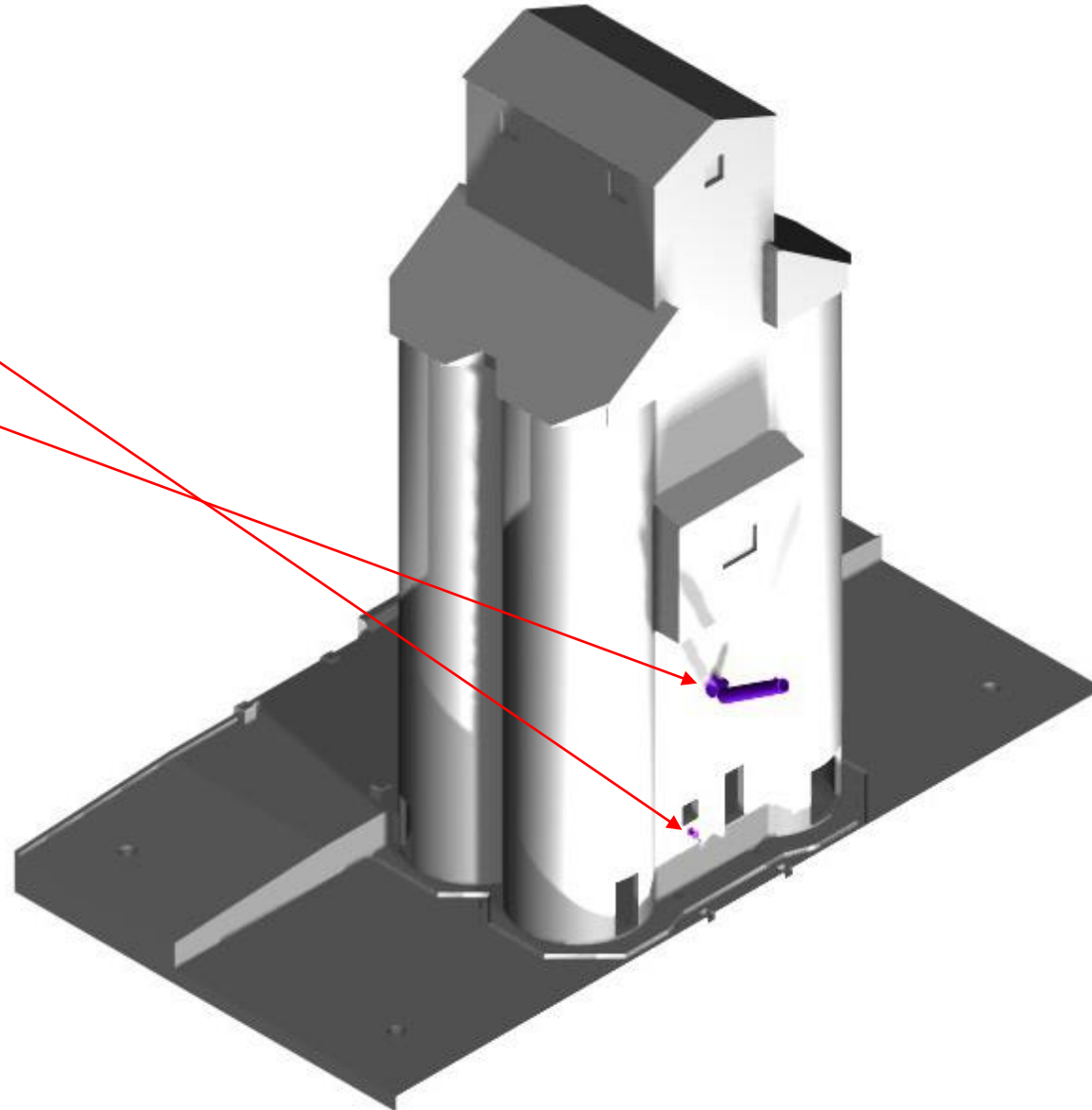

Step 50

Some of the other details are next with the out loading platform, the steps and the spoil bin.

The out loading platform fits into the 4 square holes at the front base of the silo. Fill the joint where the front of the platform fits into the base.

The front steps are then glued to the platform and the silo front wall.

The spoil bin can then be located on the base of the silo, and can be fitted basically anywhere, but it is suggested to fit it here.

The spoil bin is used to store grain that has become damaged, wet or otherwise unsuitable for use.

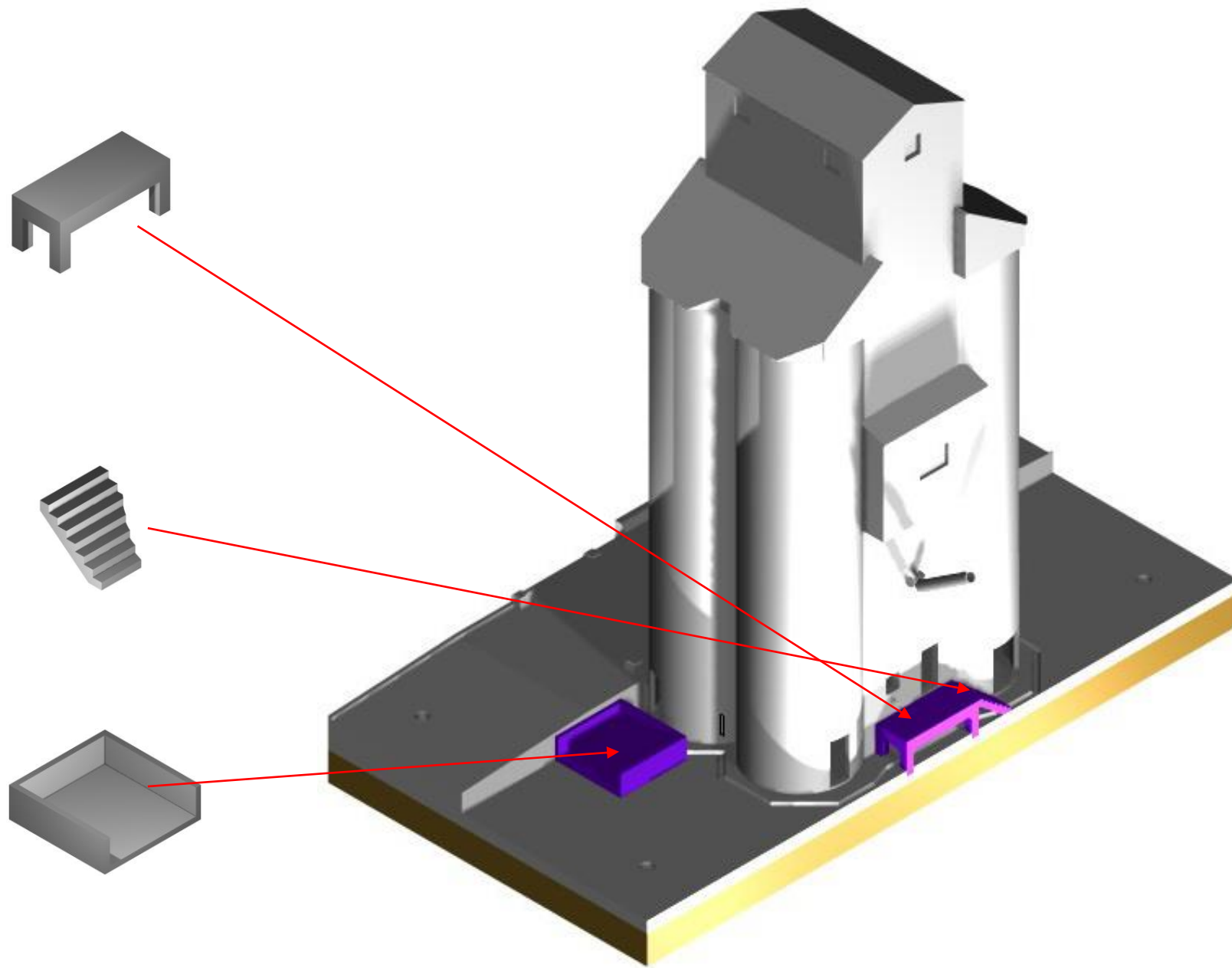

Step 51

The windows and doors come in a pack, and this slide, will show the parts and the options that the modeller has.

There are 3 types of window for the cupola, and you have the option on which to use.

Mullions



Louvered

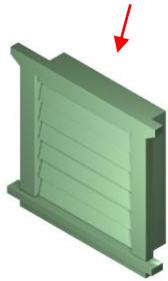

Plated



There are 3 types of window for the Annex, and you have the option on which to use.

Mullions



Louvered

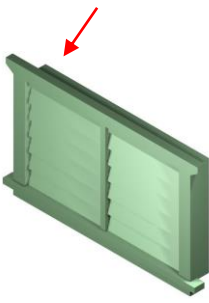

Plated

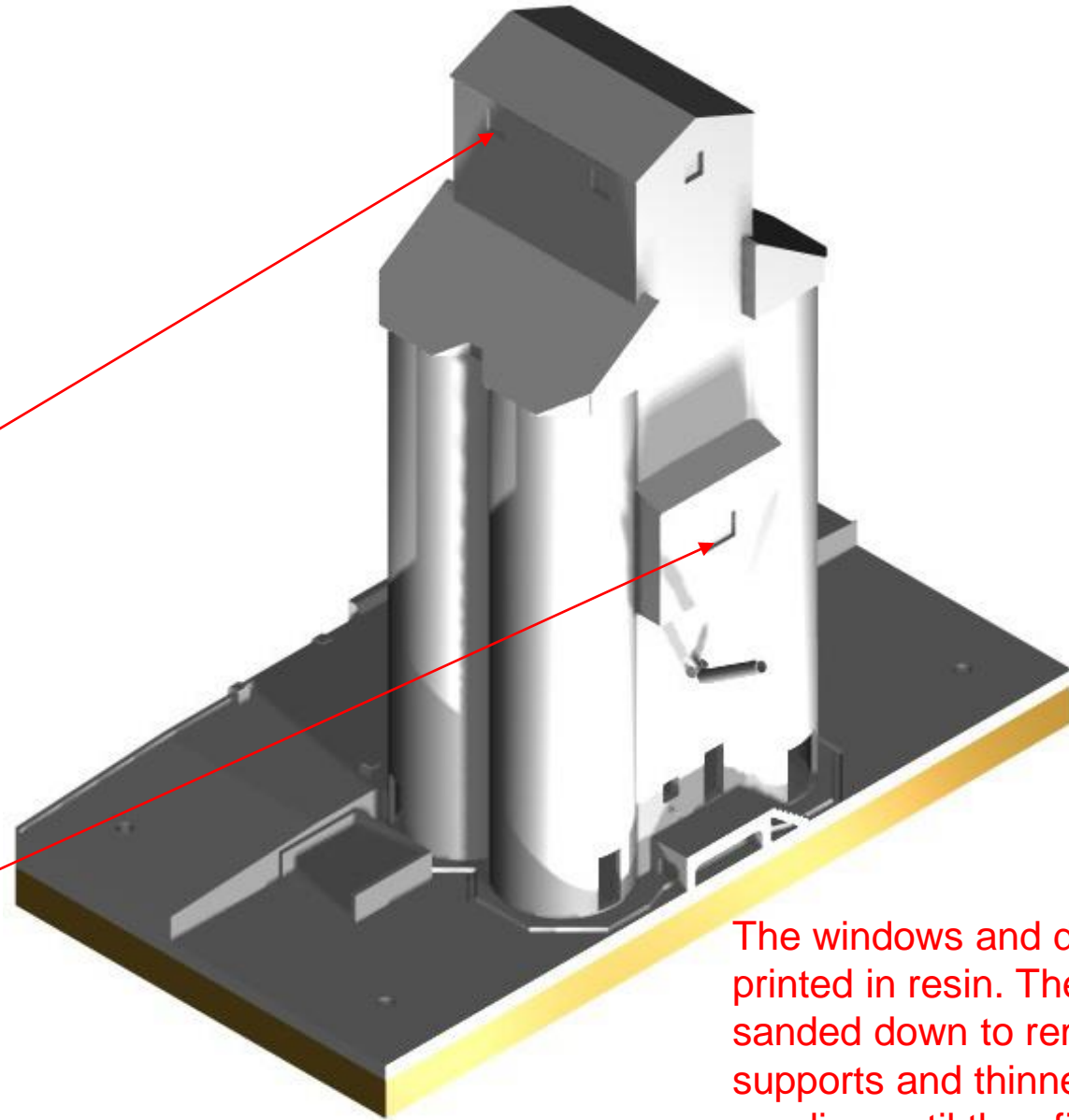
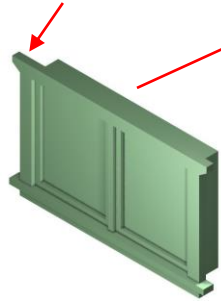

The windows and doors are 3D printed in resin. They can be sanded down to remove any supports and thinned down by sanding until they fit neatly into their own recess.

Step 52

The windows and doors come packed in a bag, and this slide, will show the parts and the options that the modeller has.

There are 4 types of Doors: Front Door x 1, Annex Door x 1, Double Door x 1, Single Steel Door x 3 , as well as a Louvered Vent x 1

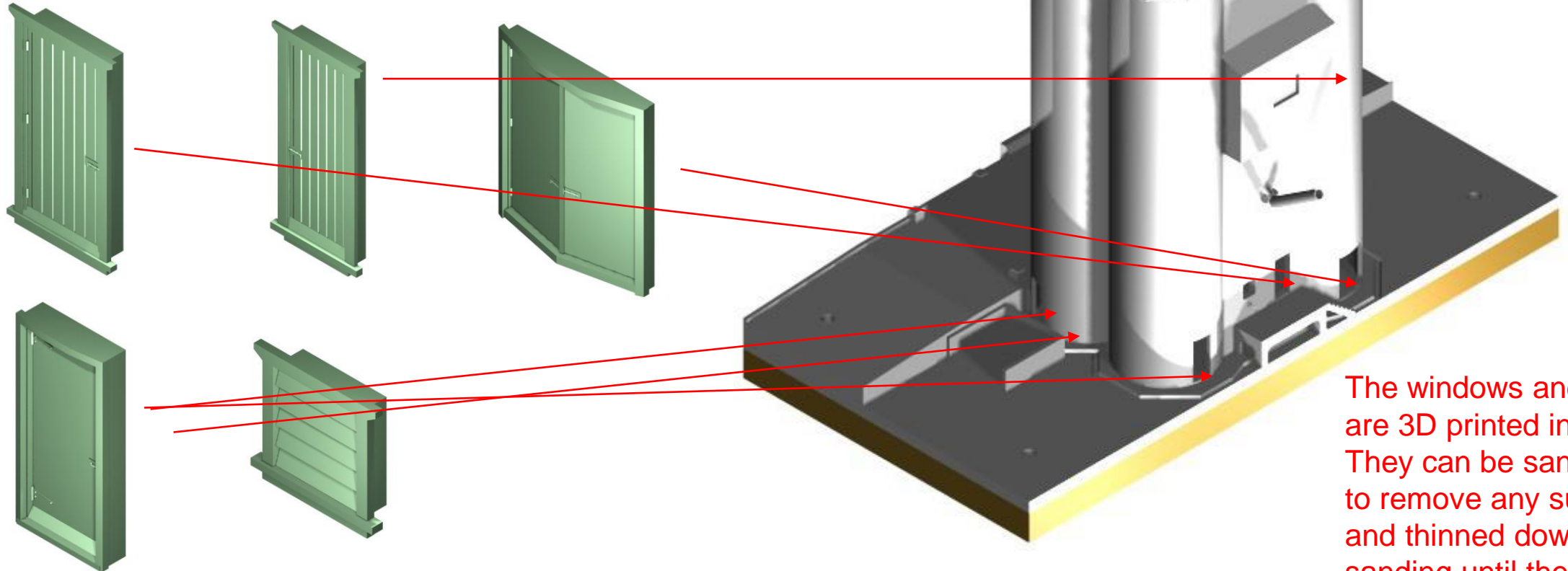

The windows and doors are 3D printed in resin. They can be sanded down to remove any supports and thinned down by sanding until they fit neatly into their own recess.

Step 53

Painting the silo is best done by looking at photos of silos. There is a huge amount of options when it comes to painting. The basic colour is concrete, but it depends on where the silo is located as to what weathering is applied.

Out west the first couple of feet would have a slightly red hue, due to the red soil and the splashback when the rain falls. I have provided photos in the flashcard provided with the instructions, feel free to use these photos to make you decision on the basic colour of the main silo.

Other colours, such as windows doors, corrugated iron, can again be made through the use of photos.

I have placed a couple of photos here for you browse, to get some idea of the colours involved.



Step 54

After painting of the basic structure, we will be fitting the wagon shed.

The wagon shed is fragile to start with, but becomes strong as it goes together.

As previously described, start by cutting and filing the brass columns to fit the jig. Sand or file the base of each column to ensure a good fit into the footing that is not too loose and not too tight. Locate the 3D plastic outer truss and purlins to the 4 brass outer columns, and secure them with glue. The outer side of the shed needs to be cut from the 2020 evergreen styrene and glued onto the 3D print and allowed to dry. This will make this outer wall reasonably rigid. Any 3D printed plastic protruding from the edge of the columns can be discarded with a file or cutting blade or sandpaper.

Place the inner truss, onto the inner columns and secure with glue, and allow to dry. Because there is no extra supports in the inner truss, be careful with handling this piece. Locate all the columns into the footings, and ensure that they are as far into the footings as possible.

Locate the 2 shed roof 3D purlins so that they butt up to each other and fit snugly onto both trusses. Only glue them into place once they are sitting square to the trusses and square to the silo back wall, and allow the glue to dry.

Cut the 2 roof sections out of the Evergreen 2020 styrene and glue these to the 3D printed roof purlins. They should also butt up square to each other and square to the silo wall. The finishing touch is to glue a length of styrene rod to the gap at the roof centre and cut a glue a strip of styrene on either side of the thin rod. This forms a ridge capping.

The same idea is also applied to the roof of the cupola.

Tip and Hints

1. Thin section of masking tape can be used to form flashing at the joints of corro panels. Photos are beneficial for this.
2. When cutting the corro panels, they should be slightly oversize to allow trimming back to size.
3. If you can sand the corro panels at 45 Degrees, where they join, this would certainly help with good joints on the roof, cupola and annex.
4. Take your time with small parts as they can be very fiddley.
5. Plan you painting to minimise repainting joints.
6. Test paint a section of similar materials before final painting to ensure that the paint you are using is compatible.
7. Spend some time with a small file/cutting blade and/or fine wet and dry, cleaning up the windows, doors and other 3D printed parts of any flash or extruded plastic.
8. You may need to test fit windows to the cupola and annex, to ensure accurate placement. Either the window or hole cut in the styrene can be adjusted as needed.
9. There are 2 plans for cutting the corro panels, just in case you bugger up cutting process. If for what ever reason you require more styrene corro. You can purchase it at most good hobby stores. --- Evergreen 2020 car siding sheet.
10. When screwing the 3D silo parts together, ensure that the surfaces are clean and free from plastic dags. Do not over tighten the screws as they are only screwing into plastic, and over tightening can strip the screw holes.
11. If any screw holes are stripped, you can glue the parts together as an alternative.
12. You can sand any of the surfaces that you wish, to whatever level you are happy with, as it is your silo and the surface detail is totally within you hands.

Conclusion

Your feedback in regard to this kit is very welcome, and will be acted upon. Especially if the issue is of a serious nature.

No doubt, there will be small glitches with any kit, and I had attempted to solve some of these problems within the instructions.

The instructions are located in 2 places, firstly they can be found as a PDF file on line at Keiran Ryan Models.

www.krmodels.com.au

They are also available as a PDF in the Flash Card that is included with the kit.

There is also a Power Point copy of the instruction on the Flash Card as well.

Also included on the Flash Card, are many silo photos which are there to assist in the finish of you silo kit. Feel free to use the photos in obtaining any information that will make the construction of this kit a better experience.

Contact details. Keiran Ryan Models ----- www.krmodels.com.au

Keiran Ryan 0409952874

krmodels@gmail.com

Thanks you for you ongoing support,

Happy Modelling Regards Keiran Ryan